



THE Pharmacologist

A Publication by The American Society for
Pharmacology and Experimental Therapeutics

Inside:

Feature articles from
2018-2019



2020 Special Edition



ASPET *CONNECT*

Your Member Community



Network, communicate, and collaborate with your fellow ASPET colleagues through ASPET's online community.

ASPETConnect's online communities allow you to network, communicate, and collaborate with your fellow ASPET colleagues anytime from anywhere. As a member you get access to discussion forums where you can connect with subject matter experts, get or give advice on career matters, or work with your committee or division members. Have a question or discussion topic? Post it on the community and allow members to provide their input. Want to see what other members are discussing? Visit your division community and scroll through the discussions.

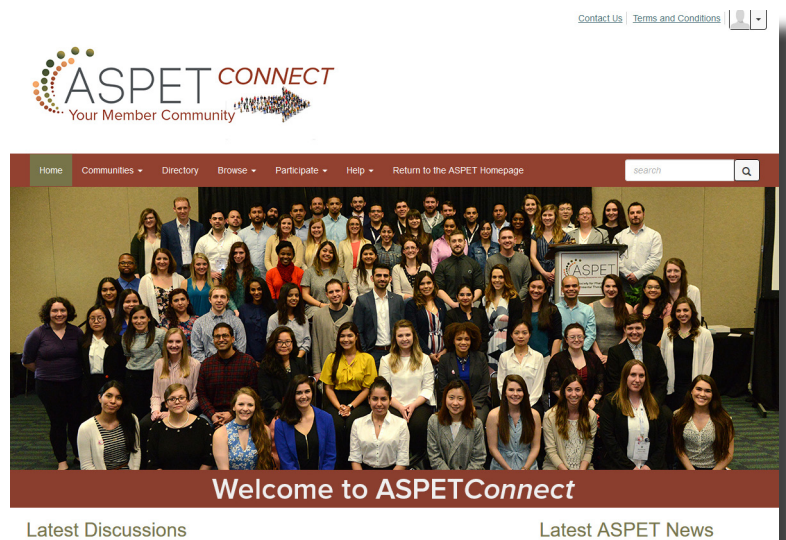

- 
- Online Communities
 - Discussions
 - Membership Directory
 - Unique Profile Pages
 - Customizable Notifications
 - Online Library
 - Communicate with Leaders

connect.aspet.org

Contents

- 1** Adventures in Pharmacology
- 2** Treating Malaria – From Gin & Tonic to Chinese Herbs
- 13** The Evolution of the Home Pregnancy Test
- 23** The Extraordinary Percy Julian
- 34** Rapamycin: The Fountain of Youth?
- 46** Sixty Years of Benzodiazepines
- 58** Viagra from NO to Yes
- 69** The Discovery and Development of Heparin
- 80** Warfarin: An Auspicious Student Project

THE PHARMACOLOGIST

PRODUCTION TEAM

Rich Dodenhoff

Catherine L. Fry, PhD

Tyler Lamb

Alexandra Monzon

Judith A. Siuciak, PhD, CAE

Suzie Thompson

COUNCIL

President

Wayne L. Backes, PhD

President Elect

Charles P. France, PhD

Past President

Edward T. Morgan, PhD

Secretary/Treasurer

Jin Zhang, PhD

Secretary/Treasurer Elect

Mary-Ann Bjornsti, PhD

Past Secretary/Treasurer

Margaret E. Gnegy, PhD

Councilors

Alan V. Smrcka, PhD

Kathryn A. Cunningham, PhD

Namandjé N. Bumpus, PhD

Chair, Board of Publications Trustees

Emily E. Scott, PhD

Chair, Program Committee

Michael W. Wood, PhD

FASEB Board Representative

Catherine M. Davis, PhD

Executive Office

Judith A. Siuciak, PhD

The Pharmacologist (ISSN 0031-7004) is published quarterly in March, June, September, and December by the American Society for Pharmacology and Experimental Therapeutics, 10801 Rockville Pike, Suite 210, Rockville, MD 20852-1633. Copyright © 2020 by the American Society for Pharmacology and Experimental Therapeutics, Inc. All rights reserved. If you would like a print subscription to *The Pharmacologist*, please contact the membership department at membership@aspet.org.

ASPET assumes no responsibility for the statements and opinions advanced by contributors to *The Pharmacologist*.

VISIT THE **ASPET CAREER CENTER** TODAY!
WWW.ASPET.ORG/CAREERCENTER/



WHAT YOU NEED: **ASPET'S CAREER CENTER** HAS IT

Jobseekers:

- No registration fee
- Advanced search options
- Sign up for automatic email notifications of new jobs that match your criteria
- Free & confidential résumé posting
- Access to jobs posted on the National Healthcare Career Network (NHCN)
- Career management resources including career tips, coaching, résumé writing, online profile development, and much more

Employers:

- Searchable résumé database
- Hassle-free posting; online account management tools
- Reach ASPET's Twitter followers (almost 2,000), LinkedIn Members (over 2,000), and email subscribers (over 4,000)
- Post to just ASPET or to the entire NHCN network
- Sign up for automatic email notifications of new résumés that match your criteria
- Job activity tracking

ASPET is committed to your success:

The ASPET Career Center is the best resource for matching job seekers and employers in pharmacology and related health science fields. Our vast range of resources and tools will help you look for jobs, find great employees, and proactively manage your career goals.



1801 Rockville Pike, Suite 210, Rockville, MD 20852-1633
Main Office: 301.634.7060
www.aspet.org

Adventures in

Pharmacology

ASPET is pleased to present the third compilation in a series of special editions of our quarterly news magazine, *The Pharmacologist*. This special compilation issue highlights feature articles written by ASPET member and science writer Dr. Rebecca J. Anderson. In each issue of *The Pharmacologist*, Rebecca focuses on science stories that take us on an adventure in pharmacology.

The eight feature articles included in this collection take us around the world and provide a view into the lives and work of some very special scientists. We travel from a farm in Deer Park, Wisconsin, where a series of dead cows led researchers to a new anticoagulant drug (*Warfarin: An Auspicious Student Project*, December 2019), to Easter Island, the “loneliest place on earth,” seeking an answer to aging (*Rapamycin: The Fountain of Youth?*, December 2018). Rebecca’s stories often provide a historical perspective, with articles touching on treating anxiety (*Sixty Years of Benzodiazepines*, March 2019) and malaria (*Treating Malaria – From Gin and Tonic to Chinese Herbs*, March 2018). Her articles also remind us of the incredible achievements of scientists such as Percy Julian (*The Extraordinary Percy Julian*, September 2018). No matter what topic, Rebecca’s articles are always compelling and informative, providing us with stories of real-life pharmacology heroes and heroines who have made a difference both in the profession and in people’s lives..

Dr. Rebecca J. Anderson



Rebecca J. Anderson holds a bachelor’s degree in chemistry from Coe College and a PhD in pharmacology from Georgetown University. She conducted postdoctoral research under an MRC fellowship at the University of Toronto. Early in her career, she conducted basic research in pharmacology and toxicology and held faculty positions at the George Washington University Medical Center and the University of Michigan School of Public Health. In parallel with her academic appointments, she served as a reviewer on several study sections of the National Institutes of Health and as a member of a U.S. Food and Drug Administration Advisory Committee.

Subsequently, she held positions of increasing responsibility for preclinical drug research at Parke Davis & Company and Boehringer Ingelheim Pharmaceuticals and for clinical drug development at Miravant Pharmaceuticals, Kendle, Covance, and Amgen. Among her research accomplishments, she served on the teams that developed gabapentin (Neurontin®) and nevirapine (Viramune®). She belongs to Phi Kappa Phi and Sigma Xi honor societies, as well as several professional societies including ASPET.

Dr. Anderson currently works as a freelance medical writer and is the author of two books, *Career Opportunities in Clinical Drug Research* and *Nevirapine and the Quest to End Pediatric AIDS*. Her writing has been recognized by the American Medical Writers Association, the Lambda Literary Review, and the Next Generation Indie Book Awards.

Treating Malaria

– From Gin & Tonic to Chinese Herbs

Rebecca J. Anderson, PhD

Malaria has plagued humans since the dawn of civilization. Wherever people settled in communities, stagnant pools of fetid water accumulated, and malaria soon followed.

The first documented cases were reported in China 5,000 years ago, in the *Nei Ching (The Canon of Medicine, 2600 BCE)*. But malaria likely originated in tropical Africa thousands of years before that (1, 2).

From Africa, malaria spread to the Mediterranean, Mesopotamia, the Indian subcontinent, and Asia, following paths created by migrating populations, expanding trade routes, and invading military forces. Spanish conquistadors and the African slave trade probably brought malaria to the New World (2).

Like many other infectious diseases, malaria causes fever, headaches, and vomiting (1). But several symptoms distinguish malaria from the rest: a hard, enlarged spleen and an atypical pattern of recurring fevers. Malarial fever “paroxysms” are sudden shifts from fever and sweating to chills and shivering in a



Patient with malaria in Nyangaton, Ethiopia.

Reprinted from <http://dx.doi.org/10.1186/1745-2917-21-26> under the Creative Commons Attribution-Share Alike 2.0 Generic License.

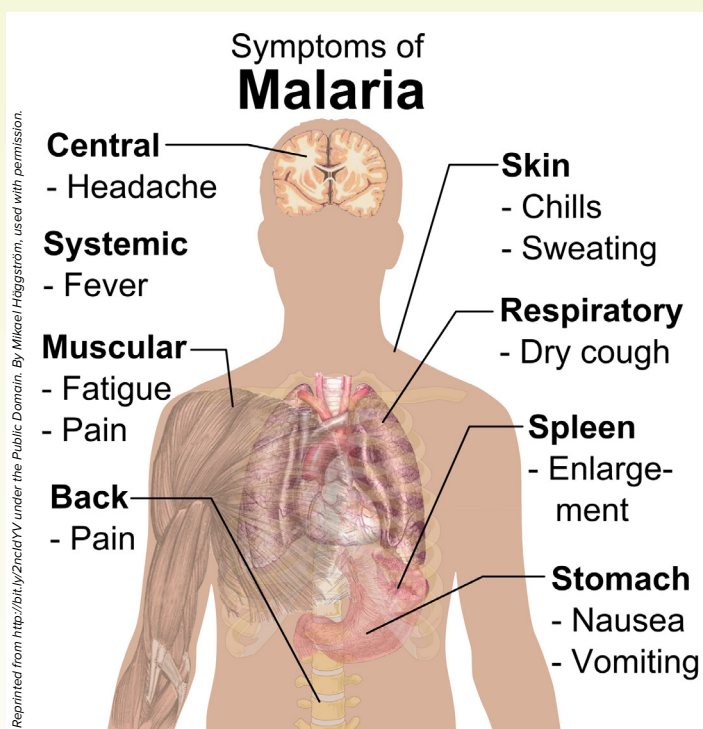

repeating cycle lasting several hours. Early physicians classified the disease as either “tertian” fever, in which the paroxysms recurred every two days, or “quartan” fever, which appeared every three days.

Everywhere in the world, the symptoms were the same, but physicians invented a variety of names for it: intermittent fever, ague, pioneer shakes, congestive fever, bilious fever, swamp fever, and marsh fever (3, 4). Long before the cause was identified, both Chinese and Western observers linked the disease to gases or evil spirits emanating from malodorous waters (4-6). “Malaria,” the name that stuck, comes from *mal’aria*, Italian for “bad air” (1, 3).

Early Treatments

Ancient practitioners probably stumbled upon the first effective malaria treatments through trial and error. In China, in 340 AD, Ge Hong first described the antifever properties of an herbal remedy, qinghao, in his *Handbook of Prescriptions for Emergencies* (1, 4, 7, 8). For hundreds of years before that, the Chinese had used qinghao for itches, malignant sores, lice, and hemorrhoids (4, 7, 8).

Subsequent to Ge Hong’s book, the use of qinghao, which comes from the *Artemisia* plant (sweet wormwood), was adopted throughout China. *Prescriptions for Universal Relief*, published in 1406, contained recipes for qinghao soup, pills, and powders to relieve malaria symptoms. In the 16th century,

Li Shizhen’s *Compendium of Materia Medica* also included qinghao preparations for curing malarial chills and fever (4, 9, 10).

The first effective remedy used by Western practitioners also came from a natural plant source. And it was also discovered by chance. In the early 17th century, Jesuit priests began establishing missions in Spanish-occupied South America. Besides saving men’s souls, the Jesuits recognized the importance of good health, and each mission included an infirmary and an apothecary. As part of their studies of botany, they sent expeditions into the wilds of Peru to gather medicinal plants (3).

In the foothills of the Andes Mountains, the Jesuits noticed that Indians sometimes drank tea made from a red bark. It seemed to cure shivering that accompanied exposure to dampness and cold. The Jesuits thought that this tree bark might also alleviate the shivering associated with malaria. They tested a preparation of the powdered bark on a few patients and found that it cured “tertian” and “quartan” fevers (3).

Encouraged by that initial success, the Jesuits began distributing samples of the bark to physicians in Lima, Peru, as well as other missions in the region (3). The bark’s curative reputation quickly spread.

Folklore pointed to the Countess of Chinchón, the wife of the Viceroy of Peru, as the most prominent advocate for this magical powdered bark. After she was miraculously cured of her life-threatening tertian fever, the Countess distributed large quantities of the remedy to the poor and sick. Grateful for her generosity, people began calling the red bark “the Countess’s Powder” (3).

After reading a description of the Peruvian tree with the red bark, Carl Linnaeus, the father of modern taxonomy, assigned it the genus *Cinchona* in 1738, in honor of the Countess. Later, he received cinchona tree specimens from an Italian botanist in Peru to add to his collection. The misspelled taxonomy assignment, which should have



Cinchona calisaya

been “*Chinchona*,” stemmed from translation of the Countess’s Spanish name to Italian by the botanist (8).

In 1930, a diary of the Viceroy’s secretary was discovered, providing a detailed contemporaneous account of the Viceroy and his family’s activities in Peru. It contradicted the fabled and much quoted story about the Countess. The diary offers no evidence that she ever suffered from malaria, or that she had ever been treated with the Peruvian bark. But after two centuries of use, the genus *Cinchona* was firmly established and has remained unchanged (3, 8).

Western Treatment of Malaria

Father Alonso Messia Venegás, an elderly Jesuit priest, carried the first small supply of cinchona bark from South America to Rome in 1631 (3). Malaria was rampant in Rome, and physicians soon found that cinchona bark was indeed an effective treatment. Juan de Lugo, a Jesuit pharmacist at the Santo Spirito Hospital in Rome and later Cardinal, became the most influential advocate for cinchona bark in continental Europe (3).

To meet European demand, the Jesuits in Peru

organized Indian laborers to harvest and process the bark. By the end of the 18th century, about 80 ships arrived annually in Spanish ports from Peru, each carrying a consignment of cinchona bark. Because of its discovery and strong advocacy by representatives of the Vatican, the red bark remedy was commonly called “Jesuit powder” or “Cardinal’s powder” (3).

Malaria was also prevalent in southern Britain in the 17th century, but the predominantly Protestant country was skeptical and critical of any medicine advocated by continental Roman Catholics (3). Also, at that time, prescriptions varied widely, and many patients suffered from the bitter powder’s side effects, including tinnitus, nausea, vomiting, and headaches.

In Cambridge, Robert Talbor, an enterprising apothecary apprentice, began studying ways to optimize dosing of the Peruvian bark and minimize its side effects. By 1670, Talbor had perfected his prescription and set up shop in London as a fever specialist (3, 8). Fully aware of the religious stigma associated with cinchona bark, he refused to divulge his recipe, saying only that it consisted of two

ingredients from England and two from abroad.

Talbor charged huge fees and was dismissed as a quack by the Royal College of Physicians, but his remedy worked. His fame—and the disdain of the medical establishment—only grew after he cured Britain’s King Charles II, as well as the Queen of Spain and Louis XIV’s son in Paris (3).

After Talbor’s death, his formulation was published in France. It consisted of rose leaves, lemon juice, and a strong infusion of cinchona bark in wine (3, 8). More important than the formulation was Talbor’s success in optimizing treatment. He lowered the conventionally used dose and administered his remedy at frequent intervals.

Dr. Sappington’s Pills

American physicians were also wary of Peruvian bark, not on religious grounds but rather because

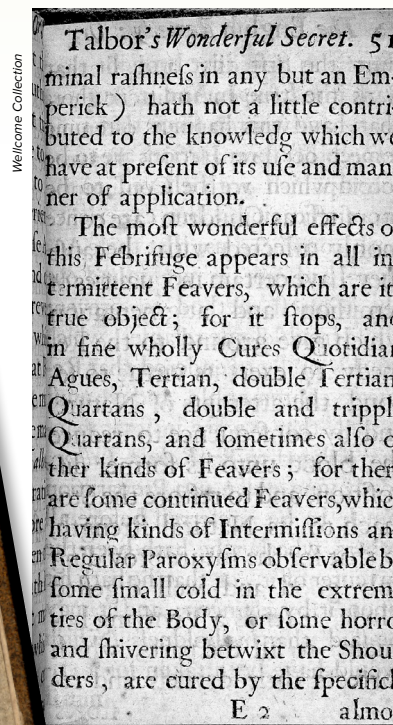
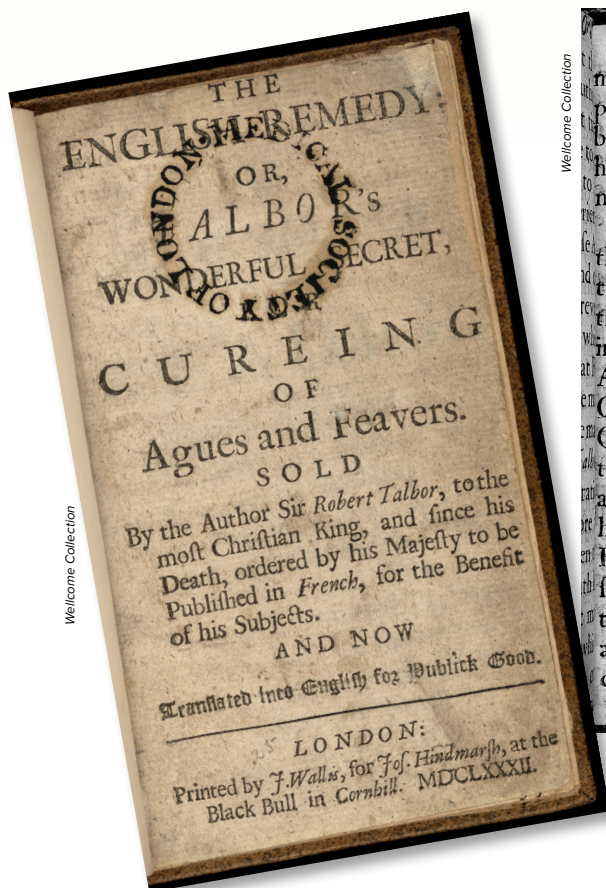

Page 51 of *The English Remedy: Or, Talbor's Wonderful Secret for Cureing of Agues and Feavers* (English translation).

The English Remedy: Or, Talbor's Wonderful Secret for Cureing of Agues and Feavers (1682). In 1682, Talbor's remedy was published in French; the English translation appeared in the same year. Front page of English translation.

they thought it exacerbated fevers (11). John Sappington, a maverick physician with “modern” ideas, challenged this notion. Born in Maryland in 1776 and raised in Nashville, Sappington apprenticed under his father, also a doctor, and set up his practice in central Missouri (3).

After practicing medicine for about five years, Sappington read an old pamphlet describing the accidental discovery and medicinal properties of the substance known as Jesuit’s bark or Peruvian bark (11). Intrigued by the account, he cautiously administered the powdered red bark to several feverish patients with good results and then did a primitive placebo-controlled experiment. Within a few hours—or a few days, at most—the bark-treated patients’ fevers broke, their thirst abated, their pulse returned to normal, and their restless anxiety (which almost always accompanies malarial fevers) would subside (11).

Sappington swallowed a ten-fold dose of the bark and convinced himself that the substance did not cause fever or increase heart rate, as many had claimed. The only adverse effect was some dizziness. He concluded that the bark’s bad reputation was due to its irritating bitter taste and that other substances in the raw bark caused the nausea and diarrhea experienced by some patients (11).

Quinine

In 1820, two French chemists, Pierre Joseph Pelletier and Joseph Caventou, isolated an alkaloid from cinchona bark and named it quinine, after *quinquina*, the Peruvian Indians’ name for the cinchona tree (3, 8, 12). Soon, industrial-scale extraction and distribution of quinine was established on both sides of the Atlantic (13).

Boehringer-Mannheim began producing quinine sulfate from bark in 1837 and became Germany’s largest manufacturer. By the end of the 19th century, it had joined two other German companies to form the first global quinine cartel (3, 8, 14).

In 1823, Rosengarten & Sons in Philadelphia began isolating quinine from cinchona bark using the Pelletier-Caventou method. Rosengarten & Sons (later acquired by Merck) became America’s largest supplier of quinine (3).

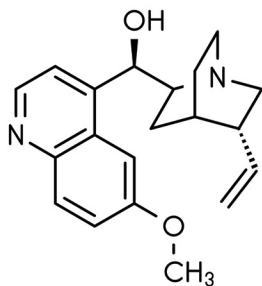

Quinine molecule

After experimenting on various patients, Sappington found it easier to optimize dosing with quinine than cinchona bark. He also concluded that quinine was far superior to blood-letting, purging, and other traditional tonics and stimulants for curing fevers (11).

Eventually, Sappington settled on a standard pill formulation that consisted of 65 mg of quinine sulfate, licorice to mask the bitter taste, a drop of sassafras oil to give “an agreeable odor,” and gum of myrrh to bind it all together (11). One of these pills every 2 hours for 2-3 days cured fevers (3, 11).

By 1832, Sappington had launched a thriving business selling Dr. Sappington’s Anti-Fever Pills. Unlike many other patent medicines, Sappington’s pills worked, making the doctor a very wealthy man. By 1836, he was ordering over 372 pounds of quinine sulfate annually—by far, Rosengarten & Sons’ biggest customer (3).



Dr. Sappington's Anti-Fever Pills

By 1844, Sappington had distributed more than a million boxes of fever pills throughout the Mississippi River Valley and the Republic of Texas. Patients, without medical supervision, were taking his pills at all stages of every type of fever. Sappington claimed “no unpleasant effects have ever within our knowledge resulted from mistakes being made in the use of the remedy” (11).

Sappington may also have been the first to ascertain quinine’s prophylactic properties, a conclusion he reached after experimental treatment of his own family and his employees (11). His 15-25 salesmen traveled to all of the endemic states and regions of America during the months when malaria was most prevalent. He told them to take one pill 3-4 times a day, “and there has never yet occurred a single instance in which any one of them has contracted a fever of any kind” (11).

Schweppervescence

Demand for cinchona bark and quinine continued to grow, driven largely by European colonial expansion. From Columbus's first expedition until the mid-19th century, European trade and colonization in the tropics were accompanied by malaria, which claimed one in ten lives annually (2). In the humid tropical regions of Africa, India, and Asia, European colonists' survival heavily depended on quinine (2, 13, 15).

In India, the British Army issued quinine in a tonic to prevent and treat malaria. By the 1850s, soldiers were adding sugar and lime to make the bitter quinine water more palatable. They were already getting a gin ration, and soon, the liquids were combined to produce the first gin and tonic (3, 16).

In the 1870s, the Schweppes Company in Geneva carbonated water containing oranges, sugar, and quinine, called Schweppes Indian Tonic Water (3). Today, Schweppes® and other brands, including Fever-Tree Tonic Water®, still contain quinine. But it is a lower quinine concentration, making tonic water less bitter—and less effective against malaria (16).

Scoping a Cause

Colonial expansion also intensified European scientists' studies of tropical diseases, especially malaria. Those researchers were greatly aided by new, high-power microscopes, and a wave of discoveries resulted. The most significant were made by Charles Louis Alphonse Laveran and Ronald Ross.

Laveran, a French army surgeon stationed in Algeria, was the first to

observe microscopic parasites in fresh blood smears of patients suffering from malaria (3, 5). In 1880, he reported his results to the French Academy of Medicine, announcing that a parasite, not bad air, caused malaria. Laveran and others (notably Patrick Manson in England) suspected that mosquitoes transmitted the malaria parasite from person to person (3).

Patrick Manson (considered by many the father of tropical medicine) strongly encouraged Ronald Ross, a British officer in the Indian Medical Service, to study malaria transmission. Guided by Manson, Ross dissected hundreds of mosquitoes that had fed on the blood of healthy and malaria-infected birds (1, 3). In 1897, he demonstrated that the malaria parasite was indeed transmitted from one victim to another by *Anopheles* mosquitoes (17).

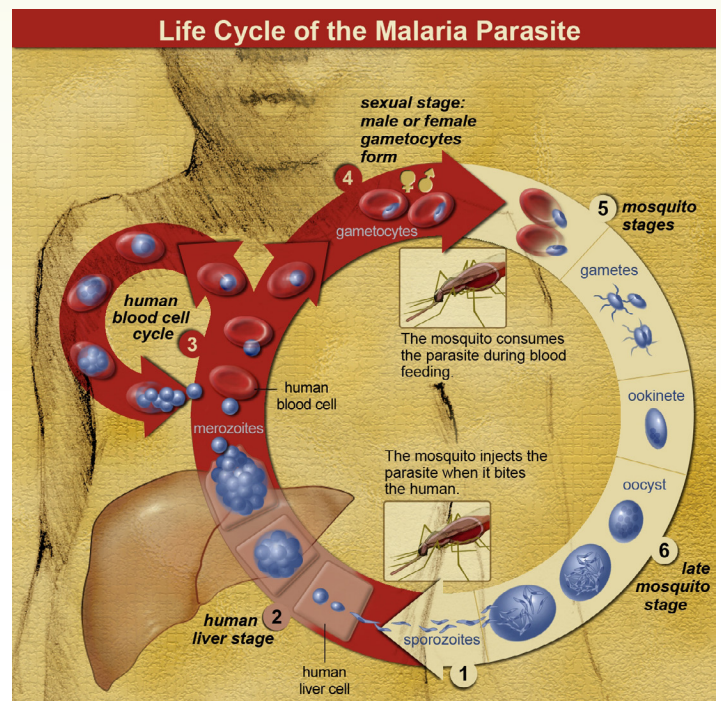

Life cycle of malaria parasites

Circumstances in India limited Ross's ability to conduct clinical studies. But convinced that Ross was right, Manson repeated the bird experiment using his own son, P. Thurburn Manson, as the subject. *Anopheles* mosquitoes, which had fed on malaria patients in Rome, were shipped by diplomatic pouch to London and used to infect Thurburn, at the time a 23-year-old medical student (18). Thurburn developed malaria, which was subsequently cured by quinine treatment. Patrick Manson also demonstrated that workers who slept in huts constructed with special mosquito netting remained healthy in a malaria-infested region of Italy (18).

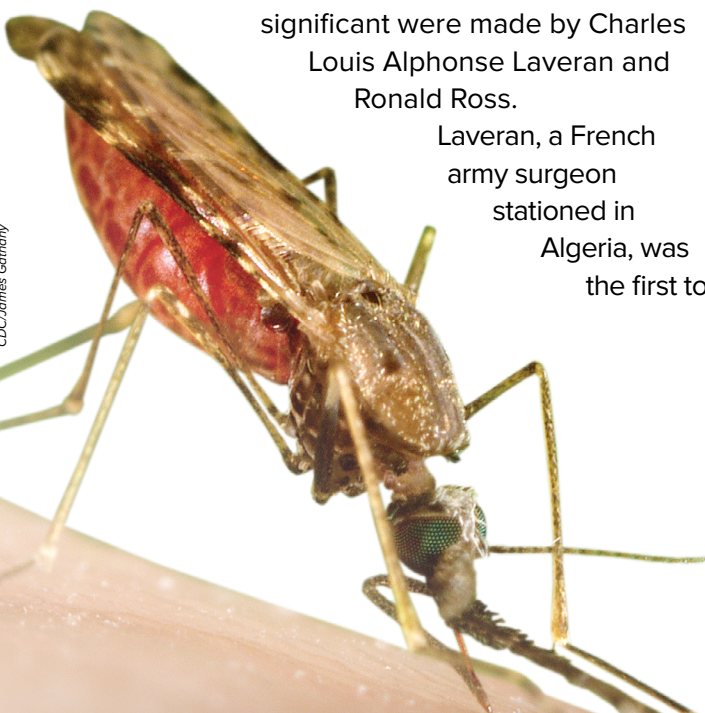

Anopheles mosquito

For their landmark contributions to understanding malaria's cause and transmission, Ross and Laveran received the Nobel Prize in Medicine or Physiology in 1902 and 1907, respectively.

Many other researchers confirmed and expanded Ross and Laveran's findings, defining the parasite's complicated life cycle, which depends on both animal and mosquito hosts. Italian researchers assigned the parasite to the genus *Plasmodium*. More than 100 species of *Plasmodium* have been identified, selectively infecting birds, rodents, monkeys, porcupines, squirrels, bats, lizards, and snakes, as well as humans (1, 3).

For their landmark contributions to understanding malaria's cause and transmission, Ross and Laveran received the Nobel Prize in Medicine or Physiology in 1902 and 1907, respectively.

Only five *Plasmodium* species infect humans. Of them, *Plasmodium falciparum* is the deadliest. It rapidly multiplies in the blood, causing severe malaria symptoms, and can clog small blood vessels. Parasitic occlusions in the brain result in cerebral malaria, leading to life-threatening encephalopathy, seizures, and coma (1). *P. falciparum* accounts for most of the 500 million malaria cases in Africa (2).

Plasmodium vivax accounts for most of the 100-300 million malaria cases in the rest of the world (2). This parasite can remain dormant in the liver for months or years after an initial infection and therefore causes recurring episodes of malarial fever and chills (1).

New Strategies

Once they learned that mosquitoes transmitted the parasite, officials tried eliminating malaria by eradicating mosquitoes. They improved sanitation, drained stagnant bodies of water, and sprayed oil on ponds where mosquitoes bred. Ronald Ross spearheaded eradication efforts during construction of the Suez Canal and in the Mediterranean during World War I. He also assisted Surgeon General William Gorgas during construction of the Panama Canal (3, 6).

Although mosquito control helped reduce the prevalence of malaria in many regions, quinine remained the mainstay for preventing as well as

treating malaria. The growing demand for quinine, especially by colonists in the tropics, made it a commodity more valuable than gold and silver (3, 8, 11). But it remained difficult to obtain, and Spain controlled the only source (8, 13).

In the early years, Jesuit missionaries conserved this precious resource by training native workers to plant 5 cinchona trees for every one they felled. Unfortunately, in 1767, the Jesuits were expelled from South America by Spain's King Charles III, who feared the religious order's growing power. Conservation efforts ceased, and aggressive harvesters systematically destroyed much of the natural cinchona growth in Peru, Bolivia, Ecuador, and Columbia (13).

Faced with this situation, various European colonial powers attempted to grow cinchona (3, 13). European-led expeditions to Peru, Ecuador, and Bolivia collected cinchona seeds and saplings for transplanting on colonial plantations. The British tried cultivating cinchona in the mountainous regions of India. The Dutch established plantations in Java and extraction facilities at the Amsterdam Quinine Company. But the cinchona tree seemed to prefer the climate in the Andes Mountain foothills, and few plants survived the long, hazardous voyage to their colonial destinations. The most successful plantations were in Germany's eastern Africa colonies, which supplied quinine producers in Germany, primarily Boehringer-Mannheim (13).

Ledger's Cinchona

At the same time, South American governments took steps to retain their revenues from this valuable natural resource. They imposed tight restrictions and high tariffs on foreigners who sought to export cinchona (3).

The most successful foreigner to run this gauntlet was Charles Ledger, a British cinchona broker in Peru who supplied London merchants. As Peruvian cinchona became harder to find, Ledger, like other brokers, searched for quality bark in virgin areas, including government-restricted areas in Bolivia. Ledger engaged Manuel Incra Mamani, a native Bolivian bark harvester, to make the hazardous journey high in the Bolivian Amazon to a site where Ledger had previously spotted a single virgin grove of lush cinchona trees (3).

Mamani and his sons patiently waited through five years of sub-optimal weather before finally harvesting a crop of high quality seeds from the virgin

grove. Then, one day, Mamani suddenly appeared at Ledger's door in Peru and delivered 40 pounds of the precious seeds (3). Ledger sent half of the seeds to his brother, George, in London, hoping to bolster Britain's advantage in the cinchona market.

By this time, British botanists had been largely frustrated in their attempts to germinate and grow the finicky cinchona tree and showed little interest. Finally, George contacted the Dutch Consul-General in London. The highly regarded Dutch botanist, F. A. W. Miquel, immediately recognized the seeds' value. At his urging, the Dutch government purchased one pound of the Ledger seeds for 100 Dutch guilders. The seeds were sent to the Dutch cinchona plantations in Java, Indonesia (3).

Ledger's seeds grew so well in Java that they transformed not just the Dutch plantations but the entire cinchona industry. The quinine content of the bark grown from Ledger's seeds averaged 14%, seven-fold higher than the typical cinchona species (3). After detailed examination, botanists determined that Ledger's seeds produced a previously unknown variety of cinchona. In his honor, the species was named *Cinchona ledgeriana*. The Dutch grafted *C. ledgeriana* onto the hardier *Cinchona succirubra*, and the resulting trees dominated cinchona cultivation (8).

Finding Substitutes

Quinine has 5 asymmetric centers and is one of 16 possible stereoisomers, making synthesis of the stereo-selective drug extremely difficult. In 1894, Friedlieb Runge tried to make quinine from coal tar and managed to produce quinoline (3). A decade later, William Perkin, a young British chemist, also used coal tar but only produced a purple goop. Realizing that this permanently staining goop might have commercial value, he called it mauveine, the first aniline dye. It not only triggered a craze for mauve fashions but also launched a new industry that produced a variety of cheap synthetic aniline dyes (15). Neither Runge or Perkin succeeded in making quinine.

By 1897, annual quinine production had soared to 85 tons, most of which was extracted from cinchona by the German cartel (13). After World War I, Germany lost its African colonies and was forced to hand over 25% of its quinine production to the Allies (3, 13). This renewed efforts by German chemists to find synthetic substitutes.

In the 1920s, German chemists at I. G. Farben screened thousands of compounds (3, 8). In 1932, they discovered Atabrine (mepacrine), which appeared to act like quinine, only better. It could prevent as well as cure malaria and had a much longer half-life (19). However, Atabrine's unpleasant side effects included psychotic reactions and yellow-tinged skin, so chemists continued the search for better alternatives (3, 8, 19).

In 1934, Hans Andersag, a chemist in the Bayer dye works division of I. G. Farben, synthesized Resochin (chloroquine), which was as effective as Atabrine (1, 20). Unfortunately, researchers over-interpreted the animal toxicology results and considered Resochin "too toxic for practical use in humans" (1, 8, 20).

Farben sent samples of Atabrine and Resochin to its US sister company, Winthrop Chemical Company. There, the drugs sat on a shelf until World War II, when Winthrop patented them (19, 20).

Controlling Quinine

Reparations imposed on Germany after World War I allowed the Netherlands to take control of the global quinine market. The Dutch consolidated their cinchona plantations in Java and their quinine extraction plants in Amsterdam into a cartel. In the 1920s, the Dutch cartel controlled 95% of the world supply of cinchona and quinine (13, 14).

In 1940, the German Army invaded the Netherlands and took control of the Amsterdam quinine inventory (8, 19). In 1942, Japan invaded the Dutch Indies, taking control of the cinchona plantations in Java (8, 13, 14, 19). Being cut off from access to quinine, the Allies pursued other ways of curing malaria.

In studies conducted in Panama, the US Army established that Atabrine was an acceptable substitute for quinine and issued it to soldiers serving in the South Pacific (3, 19). Winthrop Chemical Company had severed its ties with I. G. Farben, as directed by the Alien Properties Act, and increased domestic production. Winthrop also granted royalty-free licenses to Abbott, Eli Lilly, and Merck, further boosting Atabrine production (19).

Atabrine was effective, and its side effects (nausea, diarrhea, headaches, and yellow-tinged skin), though annoying, were tolerable. More problematic for the Army's malaria control efforts was Japanese propaganda. Rumors spread that Atabrine caused impotence, and many US soldiers went to great lengths to avoid taking it (19).

Screening New Compounds

During World War II, the US screened 16,000 compounds in a search for better synthetic antimalarial drugs, of which about 80 entered clinical trials. At Winthrop, researchers made a series of 4-aminoquinoline analogs of Atabrine and tested them against bird malaria (20). Clinical trials conducted by the US Army and Navy in 1943-1944 showed that SN-7618 was the most effective compound in the series. Winthrop named it chloroquine and later found SN-7618 was identical to Resochin, which had been sitting on the shelf since it had been shipped from I. G. Farben a decade earlier (8, 20).

Chloroquine was fast-acting and easy to administer, and contrary to the assessment by Farben scientists, its side effects were mild compared to quinine (3). Unfortunately, confusion and miscommunication during World War II caused delays in implementing production, and chloroquine was not available for general use until after the war (1, 8). In the 1950s, chloroquine became the drug of choice for both treatment and prevention of malaria (8, 21).

Unfortunately, after only 10-12 years of use, *Plasmodium falciparum* became resistant to chloroquine (1, 8). In the 1960s, this was a grave concern in Southeast Asia, where malaria is particularly troublesome and another war was raging (3, 4). In 1964, US military casualties in Vietnam due to malaria were 4-5 times higher than from direct combat (4). Fighting malaria became a top priority.

Clinicians returned to quinine, which remained effective, even against chloroquine-resistant parasites (1, 3). But quinine produced more side effects and was shorter-acting than chloroquine. Better alternatives were needed, and the US government launched the largest drug discovery program ever mounted. This malaria research effort was coordinated by Walter Reed Army Institute of Research and included numerous governmental, academic, and commercial organizations. By 1976, they had screened over 250,000 compounds and found two with commercial potential: mefloquine and halofantrine (22).

Project 523

Malaria was also devastating North Vietnam—both the civilian and military populations—and the Vietnamese government asked China for help (7). The Chinese government launched a secret military project aimed at finding a remedy for chloroquine-resistant

malaria. They called it Project 523, because the covert operation began on May 23, 1967 (7).

Over the next two years, researchers screened several thousand compounds but found no drug candidates (4, 9). In 1969, three representatives from the Project 523 national office visited the Academy of Traditional Chinese Medicine, seeking help (4). They thought that traditional Chinese medicines might provide new



Youyou Tu

leads. The Academy, in turn, appointed 39-year-old Youyou Tu to head this initiative (4, 9).

Tu, a phytochemist, had credentials in both Western and traditional Chinese medicine (23). At Beijing Medical College's pharmacy program, she trained in medicinal chemistry, phytochemistry, and pharmaceutical science under repatriated Chinese professors who had received their education in Western countries (4, 9). She graduated in 1955 and began her career in the Institute of Chinese Materia Medica of the Academy of Traditional Chinese Medicine (9).

In 1959, Tu was released from her job to participate in a two-year training program organized by the Ministry of Health. It was designed for professionals, like her, with Western medical training and introduced her to traditional Chinese medicine (9, 23). This balanced background made Tu ideal to lead Project 523's malaria research at the Academy.

Because Project 523 was a confidential, high-profile program, Tu was under tremendous pressure to complete the military project on schedule. (4) For the next few years, the search for a new malaria cure remained her top priority.

The Old is New Again

Malaria has one of the most comprehensive records in the literature of traditional Chinese medicines. Tu began by reviewing those records and interviewing experienced traditional Chinese practitioners (9). Within 3 months, she had compiled a list of 2,000

herbal, animal, and mineral prescriptions (4, 7, 9). She prepared a brochure describing the best 640 remedies and distributed it to the other Project 523 research groups (4, 9, 23).

Over the next 2 years, her research team prepared more than 380 extracts from about 20 Chinese herbs and evaluated them in a mouse model of malaria. None showed significant activity (7, 23). Then, in the summer of 1971, they saw promising activity from an extract of the Chinese herb, qinghao (*Artemisia*) (4, 7, 9). Unfortunately, the results were inconsistent and not reproducible (9).

Tu went back to Ge Hong's *Handbook of Prescriptions for Emergencies* (340 AD), the first documented description of qinghao's antifever properties (7, 4, 12). One passage caught her attention: "Take a handful of qinghao, soak in two liters of water, strain the liquid, and drink it all" (7, 9, 23). Tu realized that their standard extraction procedure, which used high temperature, may have destroyed qinghao's medicinal properties. She altered the method, extracting *Artemisia* stems and leaves at reduced temperature using water, ethanol, and ethyl ether (7, 9, 23).

On October 4, 1971, Tu tested sample 191, a qinghao ethyl ether extract (4, 9). Sample 191 completely eliminated malaria parasites in the mice. Between December 1971 and January 1972, another extract of qinghao produced 100% efficacy in malaria-infected monkeys (4, 9).

The next step was clinical trials, but their efforts were hampered by a lack of infrastructure. During the Cultural Revolution, most pharmaceutical operations in China had been shut down (7, 23). With no access to manufacturing facilities, Tu's group did the work themselves, scaling up the *Artemisia* extraction using repurposed household water vats (9).

They worked long hours in their make-shift factory, constantly exposed to large quantities of organic solvents. Insufficient ventilation resulted in deteriorated health for some members of the team, including Tu (4, 9). "This, however, did not stop our efforts" (9).

Debates over the animal toxicology results threatened to delay the start of the clinical trials. As the summer progressed, and the end of the malaria epidemic season approached, they risked having to delay the trial for a year (9).

To expedite the human safety evaluation, Tu volunteered to take the extract herself. In July 1972 and under close monitoring in the hospital, Tu and

two other team members took the extract for a week. They experienced no side effects. Five additional team members then volunteered as subjects in the dose-escalation study (9).

The first malaria patients were treated in August 1972. Qinghao relieved the fevers of all 21 chloroquine-resistant patients, and no malaria parasites were detected in their blood (4, 7, 9). The results of the mouse, monkey, and human studies were reported at a national Project 523 meeting in Beijing in November 1972 and triggered a nationwide research collaboration on qinghao (4, 9).

From Herb to Drug

In parallel with the first clinical trials, Tu's group began purifying qinghao to isolate the active substance. In November 1972, they crystallized the antimalarial compound and named it qinghaosu (7, 10, 23). (In Chinese, "su" means "basic element" (23)) In the West, qinghaosu is called artemisinin,

acknowledging its plant origin.

Tu's group had been using an *Artemisia* source locally available in Beijing, but it contained relatively small amounts of artemisinin. They determined that of the various species, fresh leaves of *Artemisia annua* contained the most artemisinin. For commercial pharmaceutical production, the Project



Artemisia annua, the source of artemisinin

523 team turned to Sichuan Province, where *Artemisia annua* is the native species (23).

With the assistance of other Chinese institutes, Tu and her collaborators elucidated the chemical structure of artemisinin in 1977. It is a sesquiterpene lactone containing a peroxy group (4, 10). While conducting structure-activity relationship studies, Tu found that the peroxy group is essential for antimalarial activity.

She also found that modifying the carboxyl group to a hydroxyl (i.e., dihydroartemisinin) not only improved

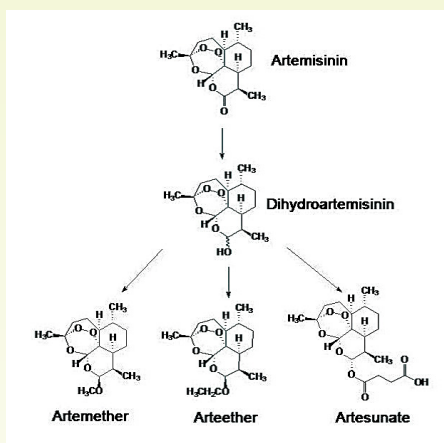

Artemisinin and its derivatives

efficacy 10-fold but also permitted synthesis of a series of analogs. Those analogs (artemether, artesunate, and arteether) were effective antimalarial drugs, and they had better pharmacokinetics than the parent compound (4, 7, 21). Subsequent studies showed that artemisinin and its analogs were more effective and faster-acting than chloroquine and quinine (7).

The prevailing environment in China restricted publication of papers on artemisinin to just a few that were published in Chinese (23). The first English language report appeared in December 1979. As was customary at the time in China, the authors were anonymous (7, 10).

The 1979 publication reported that artemisinin had cured more than 2,000 malaria patients, including more than 90% of those with cerebral malaria. Furthermore, patients experienced no serious adverse reactions (10).

The World Stage

In October 1981, the World Health Organization (WHO) invited Tu and her colleagues to present their findings to its Working Group on the Chemotherapy of Malaria (7, 23). The impressive antimalarial properties of artemisinin generated an enthusiastic response and stimulated Western interest (4, 7).

Many active analogs of artemisinin were subsequently synthesized, and this family of compounds is now the most potent and effective antimalarial therapy, particularly against chloroquine-resistant malaria (8). So far, clinically relevant resistance has not been reported, but the parasite in some regions has become increasingly tolerant to the artemisinins, requiring longer treatment schedules (8, 24).

In 2006, WHO began recommending combination therapy, to avoid emergence of resistance: an artemisinin-based compound plus a drug that acts by a different mechanism (7, 23, 24). Artemisinin-based combinations are now the standard regimen because,

according to WHO, “no alternative antimalarial medicine is currently available offering the same level of efficacy and tolerability” (4).

Over the past several decades, more than 200 million malaria patients have received artemisinin or artemisinin-based combination therapies (9). Even patients with artemisinin-tolerant malaria are cured, as long as the partner drug remains effective and treatment time is extended (7, 24).

In 2015, a research group in Singapore discovered intriguing properties related to artemisinin’s mechanism of action (25). They found that artemisinin covalently binds to 124 protein targets, many of which are involved in the parasite’s essential physiologic processes. The multiple parasitic targets help to explain artemisinin’s rapid onset, impressive efficiency, and relatively lower and slower development of parasite tolerance (25).



Youyou Tu receiving the Nobel Prize from King Carl XVI Gustaf of Sweden in 2015.

For her work on artemisinin, Youyou Tu received numerous awards by the government and other organizations in China. In 2011, she received the Lasker-DeBakey Clinical Medical Research Award. In 2015, she received the Nobel Prize in Physiology or Medicine.

In her comments to the Nobel Committee, Tu said, “Nothing can be more rewarding than the fact that artemisinin, since its discovery, has saved many malaria patients’ lives” (9).



The Pharmacologist,

Volume 60,
Number 1,
March 2018

References:

1. CDC. The history of malaria, an ancient disease; available from: <https://www.cdc.gov/malaria/about/history/>
2. Kakkilaya BS (February 25, 2015) Evolution of malaria parasites, Malaria History; available from: <http://www.malariasite.com/history-parasites/>
3. Rocco F (2003) *Quinine: Malaria and the quest for a cure that changed the world*. HarperCollins, New York.
4. Tu Y (December 7, 2015) Artemisinin—A gift from traditional Chinese medicine to the world. Nobel Lecture; available from: https://www.nobelprize.org/nobel_prizes/medicine/laureates/2015/tu-lecture.pdf
5. Kakkilaya BS (February 25, 2015) Journey of Scientific Discoveries, Malaria History; available from: <http://www.malariasite.com/history-science/>
6. Kakkilaya BS (February 25, 2015) Efforts of Malaria Control, Malaria History; available from: <https://www.malariasite.com/history-control/>
7. Strauss E (2011) Lasker-DeBakey Clinical Research Award: Tu Youyou: Artemisinin therapy for malaria, 2011; available from: <http://www.laskerfoundation.org/awards/show/artemisinin-therapy-for-malaria/#achievement>
8. Kakkilaya BS (February 25, 2015) Saga of Malaria Treatment, Malaria History; available from: <http://www.malariasite.com/history-treatment/>
9. Tu Y (2015) Youyou Tu Biography, in *The Nobel Prizes*, 2015, The Nobel Foundation, Watson Publishing International LLC, Sagamore Beach; available from: https://www.nobelprize.org/nobel_prizes/medicine/laureates/2015/tu-bio.html
10. Qinghaosu Antimalaria Coordinating Research Group (1979) Antimalaria studies on qinghaosu. *Chin Med J* **92(12)**: 811-816.
11. Sappington J (1844) *The Theory and Treatment of Fevers*. Arrow Rock, Saline County, Missouri.
12. Achan J, Talisuna AO, Erhart A, Yeka A, Tibenderana JK, Baliraine FN, Rosenthal PJ, and D'Alessandro U (May 24, 2011) Quinine, an old anti-malarial drug in a modern world: role in the treatment of malaria. *Malar J* **10**: 144; DOI: <https://doi.org/10.1186/1475-2875-10-144>.
13. Dawson RF (1991) A brief history: Quinine and quinidine production in the Americas. *Hort Technol* **1(1)**: 17-20.
14. Van der Hoogte AR and Pieters T (2015) Quinine, malaria, and the cinchona bureau: Marketing practices and knowledge circulation in a Dutch transoceanic cinchona-quinine enterprise (1920s-1930s). *J Hist Med Allied Sci* **71(2)**: 197-225.
15. Blackmore E (March 21, 2016) How malaria gave us mauve, Smithsonian. com; available from: <https://www.smithsonianmag.com/smart-news/how-malaria-gave-us-mauve-180958427/>
16. Meyer CG, Marks F, and May J (2004) Editorial: Gin tonic revisited. *Tropical Medicine and Int Health* **9(12)**: 1239-1240.
17. Ross R (1897) On some peculiar pigmented cells found in two mosquitos fed on malarial blood. *Br Med J* **2(1929)**: 1786-1788.
18. Manson P (1900) Experimental proof of the mosquito-malaria theory. *Br Med J* **2(2074)**: 949-951.
19. Smocovitis VB (May 2003) Desperately seeking quinine. *Modern Drug Discovery* pp. 57-58.
20. Coatney GR (1963) Pitfalls in a discovery: the chronicle of chloroquine. *Am J Tropical Med and Hygiene* **12(2)**: 121-128.
21. Kakkilaya BS (February 26, 2015) Antimalarial drugs, Malaria History; available from: <https://www.malariasite.com/malaria-drugs/>
22. Croft AM (2007) A lesson learnt: the rise and fall of Lariam and Halfan. *J Royal Soc Med* **100**: 170-174.
23. Tu Y (2011) The discovery of artemisinin (qinghaosu) and gifts from Chinese medicine. *Nat Med* **17(10)**: xix-xxii.
24. Ringwald P (April 2017) Status Report: Artemisinin and artemisinin-based combination therapy resistance. WHO Global Malaria Programme; available from: <http://www.who.int/malaria/publications/atoz/artemisinin-resistance-april2017/en/>
25. Wang J, Zhang C-J, Chia WN, Loh CCY, Li Z, Lew YM, He Y, et al. (December 22, 2015) Haem-activated promiscuous targeting of artemisinin in *Plasmodium falciparum*. *Nat Commun*; DOI: <https://doi.org/10.1038/ncomms10111>.



The Evolution of the **HOME PREGNANCY TEST**

In 2015, the Smithsonian Institution purchased, at auction, a little plastic box containing a test tube and an eyedropper for \$11,875 (1). The Smithsonian's curator of medicine and science called the 50-year-old artifact "revolutionary," because it symbolized a major shift in diagnostics. The little kit allowed women to test their own urine and determine for themselves whether or not they were pregnant (2).

Ancient Urine

The concept of using urine to diagnose pregnancy dates back to at least 1350 BCE. An ancient Egyptian papyrus described a test that involved having women urinate on wheat and barley seeds for several days (3). If the barley seeds sprouted, the woman was pregnant with a boy. If the wheat seeds grew, it meant a girl. If neither sprouted, the woman was not pregnant.

In 1963, scientists demonstrated that the Egyptian procedure, though simple and lacking scientific precision, was 70% accurate (3). Urine from pregnant women did promote growth of the seeds, whereas the urine of men and non-pregnant women did not.

In the centuries that followed, healers and other practitioners increasingly asserted their diagnostic expertise. They claimed they alone could perform the complicated and often mysterious, ritualistic procedures. In the Middle Ages, for example, physicians made various diagnoses by visually inspecting urine. Clear pale lemon-yellow urine with a cloud on its surface indicated pregnancy (3). Other practitioners mixed urine with wine or sulfur and assessed the precipitates (3, 4). None of those methods proved reliable.

In the 18th and 19th centuries, some physicians suggested that pregnant women secreted certain substances into their urine. Those substances, which were visible only under a microscope, were probably bacteria or crystalline materials (4). In the 1890s, Ernest Starling coined “hormone” as the name for secreted chemical messengers (3).

The Rabbit Died

In the 1920s, scientists identified a specific hormone, human chorionic gonadotropin (hCG), which they found only in pregnant women (3). In 1927, two German gynecologists, Selmar Aschheim and Bernhard Zondek, injected urine from pregnant women into immature female mice. The injection induced an estrous response in the mice despite their immaturity. No such reaction occurred after injection of urine from non-pregnant women (3, 5). Aschheim and Zondek concluded that the urine of pregnant women contained a substance that resembled pituitary hormones (3, 5, 6).

From this observation, the “A-Z test” was standardized and adopted as a routine, though somewhat cumbersome, test for pregnancy. Five immature female mice were injected with a woman’s urine twice daily for 3 days, and then their ovaries were examined. Enlarged and congested mouse ovaries indicated that the woman was pregnant (6).

Maurice Friedman, who had earned PhD and MD degrees from the University of Chicago, improved on the A-Z test, although he admitted it was “something of an accident” (7). In 1928, Friedman joined the University of Pennsylvania Medical School, where

he taught and conducted research in reproductive physiology (8). He was interested in the “peculiar and special mechanism of ovulation in the rabbit” (7).

Female rabbits have an almost constant supply of ripe ovarian follicles, but the follicles are discharged only after mating with a male. The prevailing view was that rabbit ovulation was a neural reflex, but Friedman (using transplanted ovaries with no innervation) demonstrated that a hormonal mechanism was involved. To prove the point, he needed a source of suitable hormones for his next experiments. “I really wanted to use hog pituitaries but...my greatly restricted research funds forced [me] to seek some other material” (7).

At about the same time, he read the reports of Aschheim and Zondek, indicating that the urine of pregnant women contained something that resembled pituitary hormones. At first, he was skeptical, “because at that time bizarre claims were being made in the European literature” (7). But due to his limited research funds, “I had little choice in the matter” (7). Coincidentally, his lab was next door to the Obstetrics Division of the hospital, and he prevailed upon his good friend, Max Lapham, a resident in obstetrics, for urine specimens (7).

Friedman injected urine from pregnant women into a series of female rabbits and examined their ovaries 24-48 hours later (9). The rabbits’ ovaries developed corpora lutea and corpora hemorrhagicum—ovulatory changes that occur after mating and presumably were due to hormones in the urine (8). The best results came from rabbits that had delivered a litter within the previous few weeks (9). Friedman thought his method was “sufficiently accurate for clinical use” and made no further attempts to optimize it (7). In fact, ovulation was so consistent that a single postpartum rabbit could be used to determine a woman’s pregnancy. Friedman said, “The only more reliable test is to wait nine months” (8).

In 1932, Friedman recommended that “the postpartum rabbit be given a trial in the bioassay of gonad-stimulating extracts” (10). He admitted that this rabbit test was no great discovery—merely a modification of the A-Z test. But within a few years, many clinicians adopted Friedman’s test because of its “regularity, rapidity, and ease” of use (7, 10, 11).

At Mount Sinai Hospital in New York, for example, Frank Spielman used Friedman’s test to assist with diagnosing 635 difficult cases. Spielman not only

could diagnose normal pregnancies but also detected ectopic gestation and incomplete abortions (11). He concluded, “The Friedman test is worthy of universal adoption” because the method gives “results as good as those obtained with mice” (1). The rabbit test was also faster and used fewer animals.

“The rabbit died” became a euphemism for a pregnancy diagnosis. In fact, the rabbits (and mice) always died because they had to be dissected to examine the size and condition of their ovaries (5).



African clawed frog, *Xenopus laevis*

Leap Frog

An even faster bioassay was developed by F. A. E. Crew using the African clawed frog, *Xenopus laevis* (12). Crew’s assay was an application of research conducted by Lancelot Hogben, Crew’s deputy at the Animal Breeding Research Department of the University of Edinburgh (6).

Hogben was a talented endocrinology researcher and cofounder of the Society for Experimental Biology, but he also held strong socialist views and considered himself a “scientific humanist.” He railed against the then-popular eugenics movement and was imprisoned in Britain as a conscientious objector during World War I—after working with a Red Cross ambulance unit in France (6).

In addition to his work in Edinburgh, Hogben briefly held appointments in London and Montreal before accepting a lucrative professorship at the University of

Cape Town, South Africa (6). He continued his studies of comparative endocrinology, most of which used *Xenopus*, a species plentiful in South Africa. Among his findings was that injection of ox anterior pituitary extracts induced ovulation in the female frogs.

Hogben became increasingly troubled by the racism and worsening political climate in South Africa. After three years, he returned to London, where he accepted the chair in social biology at the London School of Economics.

In his basement laboratory, Hogben set up a colony of *Xenopus* and, along with his colleague Charles Bellerby, optimized the conditions for maintaining healthy frogs in captivity (6). Among other things, their research showed that in the absence of males, the females do not lay eggs spontaneously (5, 12). However, isolated female *Xenopus* could be induced to lay eggs when challenged with an appropriate stimulus, such as urine containing gonadotropins.

Hogben was more interested in reproductive physiology research than assay development. But he sent some frogs to Crew, his former boss in Edinburgh, and encouraged him to investigate their suitability for pregnancy testing (6). Crew’s method involved injecting a woman’s urine into the frog’s dorsal lymph sac. If the woman was pregnant, the female frogs laid eggs 8-12 hours later, a response that could be observed without dissection of the animals (6). Initially, Crew and other research groups used this *Xenopus* method only for experimental studies in their laboratories (12).

In 1937, Crew compared the features of the A-Z mouse test, the Friedman rabbit test, and the *Xenopus* test. He called the frog method the “Hogben test,” acknowledging Hogben’s seminal studies (12). Each of the three bioassays had advantages and disadvantages, but Crew concluded that they all were trustworthy. The A-Z test gave results in 5 days, the Friedman test took 1-2 days, and the Hogben test took less than 15 hours (12).

Crew’s lab, as well as commercial laboratories, offered their services to doctors and hospitals for animal-based pregnancy testing. Over the next 2 decades, they each performed tens of thousands of tests (6). As the bioassays became more widely available, popular books on prenatal care and childbirth began encouraging women to visit a doctor’s office and take advantage of the tests to confirm their pregnancy (3). Unfortunately, all of these bioassays

were labor-intensive and relied on trained technicians to care for the animals, dose them, and assess the signs of ovulation.

From Animals to Test Tubes

In 1960, Leif Wide and Carl Gemzeill developed a hemagglutination inhibition test for pregnancy (3, 13). In 1966, A. Rees Midgley published the first radioimmunoassay for gonadotropins (14). These tests were faster and less expensive than the animal assays, but they could not distinguish between hCG and the closely related gonadotropin, luteinizing hormone (LH) (3).

Although by the 1960s hCG was well established as a hormone associated with pregnancy, little else was known about it. The National Institutes of Health (NIH) was one of the few places in the US conducting reproductive endocrinology research (3). Among those NIH researchers were Judith Vaitukaitis and Glenn Braunstein.



Judith Vaitukaitis. © In the public domain

They had both been medical residents in Boston and arrived at NIH's National Cancer Institute in 1970 to begin research in the Reproductive Research Branch under Griff Ross (3). Vaitukaitis worked as an NIH postdoctoral fellow. Braunstein held a commission as a Clinical Associate in the US Public Health Service, which fulfilled his military obligation. The alternative for him was Vietnam.

Using various techniques, researchers at NIH and elsewhere determined that hCG consists of two subunits. The alpha-subunit of hCG is identical to the corresponding subunit of LH, which explained why antibodies raised to the intact hCG hormone cross-reacted with LH in the early immunoassays.

In 1970-1971, Vaitukaitis worked long hours in 10B09, a small lab in NIH's Building 10, studying hCG (3). She immunized rabbits with each hCG subunit, harvested the subunit-selective antibodies, and studied their characteristics and biological function. Most of her research focused on the beta-subunit of hCG because it was structurally and immunologically distinct from the other gonadotropins.

In 1972, Vaitukaitis injected five rabbits with 10 µg of the isolated beta-subunit, and then five rabbits with 50 µg. SB6, the first rabbit to receive the 50 µg injection and the sixth rabbit in the experiment, was the first rabbit to produce an hCG-selective antibody (15).

Vaitukaitis and Ross showed that the SB6 antiserum bound only to hCG—unlike antibodies raised to the intact hormone, which were non-selective (15). “SB6 became the classic antiserum,” Vaitukaitis said. “[It] had the best relative specificity...and we provided it all over the place” (3).

Choriocarcinoma and Beyond

Years earlier at the National Cancer Institute, Roy Hertz had investigated experimental treatments for choriocarcinoma, a tumor that secretes hCG. He and his colleague Min Chiu Li monitored hCG in the patients' urine to track how well the chemotherapy drugs were working. In groundbreaking research, they persisted with methotrexate treatment until the patients' hCG was undetectable. The tumors dramatically shrank—the first time that any solid tumor had responded to chemotherapy. But Li's assay did not distinguish between hCG and closely related gonadotropins.

Citing Vaitukaitis's work, Braunstein asked Griff Ross whether they could develop a radioimmunoassay that was specific for hCG. In Ross's lab, Vaitukaitis and Braunstein proceeded to purify the antibody and developed a quantitative method for detecting hCG in blood. They did not have to look far for blood samples. Taking advantage of the clinical resources at NIH, they assayed samples taken from patients during routine blood draws. In some of those blood samples, their new assay detected measurable levels of hCG (3).

They also assayed frozen serial samples that Ross had collected from women with choriocarcinoma. In some women who had undergone chemotherapy treatment and had supposedly been cured, Vaitukaitis and Braunstein were still able to detect small amounts of hCG (15).

They knew that their radioimmunoassay, because of its specificity and sensitivity, would be quickly adopted by commercial firms (3). Its value in monitoring cancer chemotherapy efficacy alone justified a patent. Before publishing their research in 1972, they met with NIH's patent lawyers (3).

"We wanted to protect the public from getting gouged with being charged for these tests," Vaitukaitis said, "but the legal counsel would not at that time

allow patenting" (3). Their work had been conducted using public funds, the lawyers said, and the results belonged in the public domain. NIH did not patent the assay.

At first, the new radioimmunoassay was used by clinicians who were treating and monitoring patients with hCG-secreting tumors. According to Vaitukaitis, "We were doing assays for people all over the place. We felt ethically that we had to because it wasn't available anyplace else. So, we used to give out a lot of antisera to research labs and show them how to set up the assays" (3).

Although most of their data was collected from cancer patients, Vaitukaitis and Braunstein noted in their 1972 paper that "the sensitivity of the assay will permit earlier diagnosis of pregnancy" than the commercially available alternatives (15).

A Lightbulb Moment

Technicians in clinical chemistry labs were already using immunoassays to conduct the routine pregnancy tests ordered by doctors (3). But now, commercial developers drew on the work of Vaitukaitis and Braunstein to devise assays with greater sensitivity.

Some of those developers also offered urine-pregnancy testing services. Among them was Organon Pharmaceuticals. One day, Margaret Crane visited Organon's commercial laboratory in West Orange, NJ, and noticed row upon row of test tubes suspended over a mirrored surface. She asked a scientist and was told they were pregnancy tests: "Each test tube contained reagents which when combined with a pregnant woman's urine, would display a red ring at the base of the test tube, as reflected in the mirror" (1).

All of the pregnancy testing up to that time required doctors to send their patients' urine samples to a local clinical chemistry lab or ship them to a commercial lab like Organon's. Technicians conducted the assay and returned the results to the doctors. The doctors then notified their patients by telephone or mail. The entire process took up to 2 weeks (2).

"I thought how simple [the assay] was," Crane said. "A woman should be able to do that herself" (1). She knew many women wondered whether they might be pregnant, but for social, legal, or religious reasons, they remained silent—and worried.



Margaret Crane. © Reprinted with permission from Ashley Gilbertson/VII/Redux

Unmarried women often avoided pregnancy testing because they did not want their doctor to know they were sexually active (16). In 26 states, obtaining birth control was illegal (17). In the workplace, bosses had the right to lay off women who became pregnant. Abortion was generally illegal in the US, and Crane knew a number of women who had gone through great soul-searching and, for some, the dangerous process of seeking and getting an abortion (17).

Doing Homework

Organon had hired freelancer Margaret “Meg” Crane in 1967 to design a new line of cosmetics packaging (1). The 26-year-old graphic designer was not a scientist and had no particular chemistry background (2). After her visit to the testing labs, Crane returned to her home in New York and made a few attempts at designing a self-contained urine test that women could do at home. Her attempts failed.

Then one day, she absentmindedly glanced at a little plastic box on her desk. It held paperclips. The rectangular container, she instantly realized, was the right size and shape for holding the components of the urine test.

In place of the mirror, she cut a piece of Mylar to fit at an angle at the base of the box. Above that, she placed a shelf with holes to hold a test tube and an eyedropper (1). A woman would collect a urine sample using the box’s lid and then squeeze a few drops of it into the test tube. By peering through the transparent wall of the box, she could watch the bottom of the test tube as reflected by the Mylar mirror. A red ring would magically appear if she was pregnant (17).

Crane took her model to work, but her managers were not interested. Organon marketed its pregnancy testing services to doctors, and Crane’s product would eliminate the doctors’ need for such services (17). Some managers objected on moral grounds, fearing that women who did their own tests would be more likely to seek abortions, and that would bring the wrath of church hierarchies on the company. Others simply said women had no right to test themselves for pregnancy (1).

Disappointed but not discouraged, Crane returned to the office that she shared with a secretary, tucked away her prototype, and resumed sketching lipstick cases and cosmetics bottles (17). Although no one told her, the idea of a home pregnancy test remained on the minds of Organon’s executives (1).

A few months later, Organon’s Vice President visited AZKO, the parent company in the Netherlands, and pitched the concept to his bosses. The Dutch executives approved and gave him a small budget to conduct a marketing assessment (1). The project moved forward, despite the American managers’

Others simply said women had no right to test themselves for pregnancy.

objections. Those skeptics became more supportive when they saw the favorable sales projections (1).

In January 1968, Crane learned that a strategy meeting had been scheduled to discuss the design of Organon’s new home pregnancy kit. She had not been invited, but she decided to attend anyway (17).

On the conference room table, her boss and a group of freelance product designers had lined up their proposed models. Crane entered the room and slid her jury-rigged prototype in line with the others. She took a seat at the table and glanced at her boss, challenging him to throw her out. He didn’t (17).

The competing models—all designed by men—had little flowers around the edges or purple diamonds. One had a tassel on the top (2, 17). To Crane, they didn’t look scientific. “If I were a customer,” she said, “I’d worry about how accurate they could be” (2).

Then, Ira Sturtevant entered the room. He had been hired to manage the marketing plan. After inspecting the prototypes, he picked up Crane’s model and said, “This is what we’re using, isn’t it?” (17).

Her boss replied, “No. That’s just something Meg did for talking purposes” (17). He claimed it would be too expensive to manufacture. That was not true, and in the end, Crane’s model was chosen over the others. It was the only design that allowed customers to reliably conduct the assay and view the results (17).

In 1969, Organon applied for a patent on the kit design and listed Crane as the inventor (18). In a little ceremony with the company’s lawyers and executives, Crane signed over her patent rights to Organon for \$1 (1, 4, 17).

In 1970, Crane and Sturtevant joined forces to form Ponzi & Weill, Inc., a design consulting firm, and Organon hired them to manage the product’s market launch in Canada (1, 2, 17). When the kit (labeled “Predictor”) appeared on Canadian store shelves in 1971, the slogan was, “Every woman has the right to know whether or not she is pregnant” (17).

May 18, 1971

M. M. CRANE
 DIAGNOSTIC TEST DEVICE
 Filed Jan. 22, 1969

3,579,306

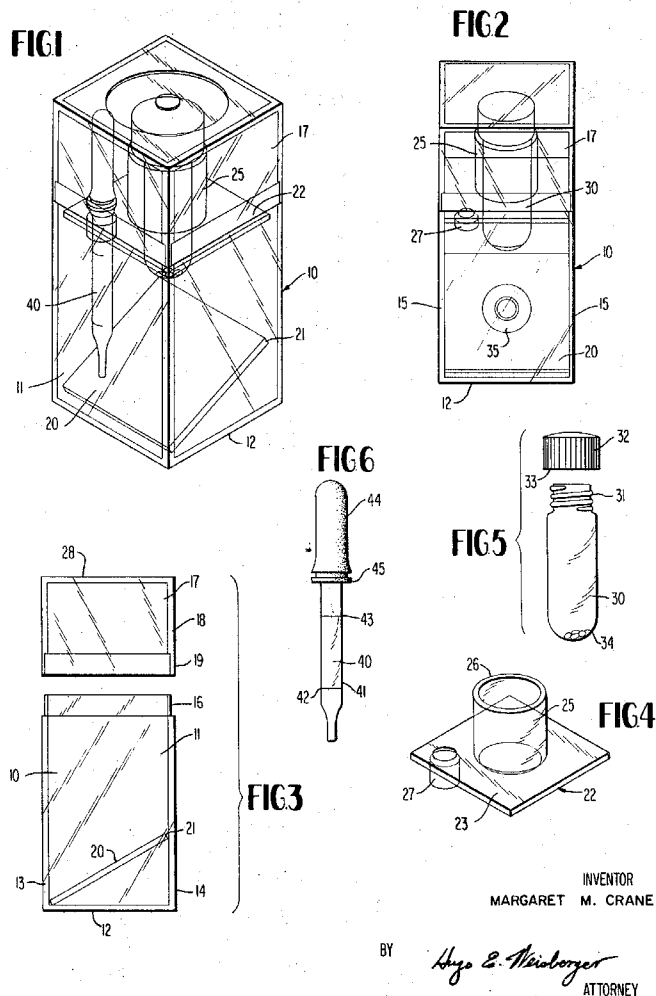

INVENTOR
 MARGARET M. CRANE

BY *Arno E. Weinberger*
 ATTORNEY

Patent for home pregnancy test (US3,579,306) by Margaret Crane. © In the public domain

The Predictor kit was an immediate hit in Canada, but it triggered a vigorous debate in the US. The US Public Health Service opposed the product because they feared that teenaged girls would be the main customers (17). The Texas Medical Association warned that if women diagnosed their pregnancy without seeing a doctor, they would neglect prenatal care. Some doctors questioned the ability of women to accurately administer home tests, especially when they were “in a state of emotional anxiety” (17).

Changing Times

Organon licensed its patented product to several companies for marketing in the US (2). All of these companies based their home pregnancy products on the kit design and antigen-antibody reaction described in the Crane-Organon patent (16, 18).

The reagents were contained in two pellets or tablets, which were placed in the test tube. The first contained a freeze-dried, predetermined quantity of sheep red blood cells sensitized with hCG. The other contained a freeze-dried, predetermined quantity of rabbit hCG antiserum. The woman added distilled water and a few drops of her urine to the test tube. If hCG was present in the urine, the antibodies bound to it and the sheep cells fell out of solution forming a distinctive red ring in the bottom of the tube. If there was no hCG in the urine, the rabbit antibody agglutinated to the sheep cells and formed a dense clump (16, 18).

Warner/Chilcott, a division of Warner-Lambert Company, sponsored clinical trials with its in-licensed product. Howard McQuarrie in Utah and Veasy Butram, Jr. in Texas enrolled 379 women who used the kit in their homes. Their test results were 97% accurate in identifying pregnancy, and that was comparable to the results obtained by trained laboratory technicians (16).

Warner/Chilcott’s product e.p.t. (for “early pregnancy test”) was the first home pregnancy test approved by the US Food and Drug Administration. It appeared on US store shelves in early 1978 (16). Later that year, e.p.t. received competition from “Answer” marketed by Diagnostic Testing, Inc., a subsidiary of Carter-Wallace; “ACU-TEST” marketed by J. B. Williams, Inc., a subsidiary of Nabisco; and “Predictor” marketed by Whitehall Laboratories, a subsidiary of American Home Products (16).

Women had no difficulty following the package’s instructions, despite the multiple, time-consuming steps (16). The label on the box included a warning, “Keep refrigerated” (2). One woman recalled, “I had to refrigerate the urine. The test could not be disturbed. You had to put it where it would not feel any vibration” (19). And women had to wait two hours for the ring or clump to appear in the tube.

Though clunky, the Predictor and e.p.t. kits were groundbreaking. For the first time, women could find out whether they were pregnant in the privacy of their own bathrooms. And, just as noteworthy,

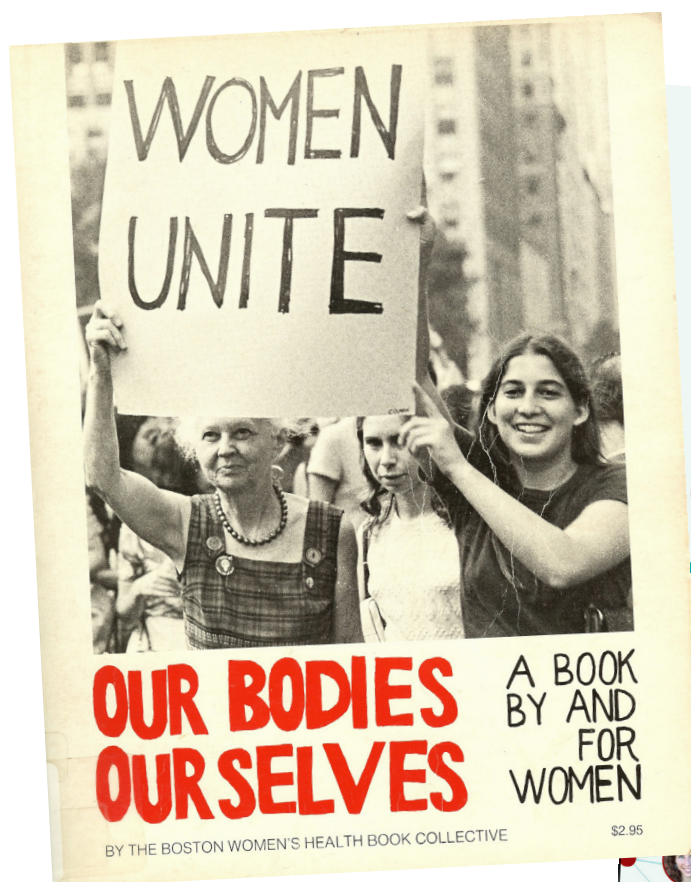

First edition of *Our Bodies, Ourselves* in 1973 (left) and latest edition of *Our Bodies, Ourselves* in 2011 (right) © Reprinted with permission from *Our Bodies Ourselves* (www.ourbodiesourselves.org)

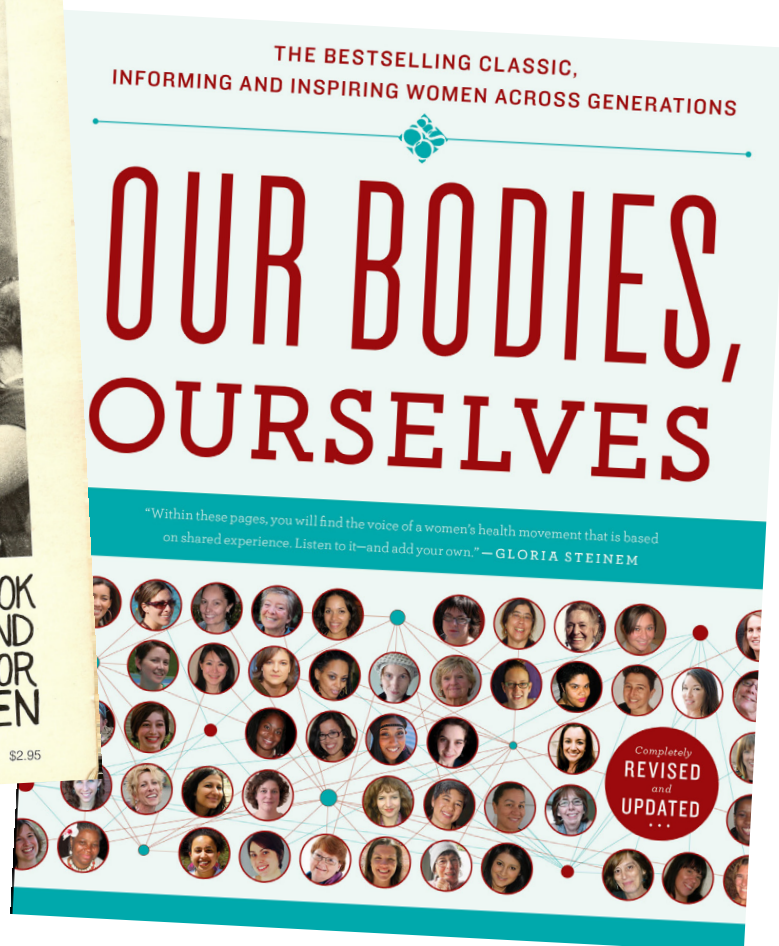

they were taking an active role in their healthcare (4, 16). As Cari Romm explained, “The home pregnancy test wasn’t just about knowing; it was about taking charge, a sentiment that fit in nicely with the ethos of the time” (4).

In 1972, Title IX of the US Civil Rights Law ensured equal participation and benefits to women regarding

“The home pregnancy test wasn’t just about knowing; it was about taking charge, a sentiment that fit in nicely with the ethos of the time”

education and all activities receiving federal financial assistance. In 1973, *Our Bodies, Ourselves* was first published—a book in which women frankly addressed topics that had been regarded as taboo (postpartum

depression, abortion, birth control, and sexual orientation), as well as pregnancy, childbirth, and menopause. Also in 1973, the US Supreme Court declared abortion legal in *Roe v. Wade*. Women’s liberation groups felt more emboldened to assert women’s rights.

Home pregnancy tests were heavily advertised in women’s magazines, but in preparing the ads, marketers struggled to find ways to describe their product. They avoided technical terms such as “hCG,” but other details such as “urine stream” were necessary and difficult to sugar coat.

The ads emphasized the products’ benefits: For \$10, any woman could answer her question about pregnancy in the privacy of her own bathroom without involving husbands, boyfriends, bosses, or doctors (17). One ad for e.p.t. called it “a private little revolution that any woman can easily buy at her drugstore” (3, 4). A Predictor ad boldly asked, “Pregnant? The sooner you know, the better” (3).



Home pregnancy test

Concerns about enabling promiscuous behavior proved to be unfounded. Rather than teenaged girls, the kits appealed primarily to college coeds and married women who eagerly wanted to start a family (17).

Still, some doctors remained skeptical. One wrote to the *American Journal of Public Health* saying that untrained women might use the tests incorrectly and do more harm than good. The journal's editors firmly backed the home pregnancy test and replied that incorrect temperature and blood glucose measurements might be even more dangerous, but patients routinely performed those tests at home. "Not everyone needs carpenters to hammer in their nails" (20).

The Thin Blue Line

The popularity of home pregnancy testing prompted competition among manufacturers to simplify the test procedure and streamline the packaging. A wide range of home pregnancy products flooded the market. Some, like the original, were "cup kits." Others used test strips or dip sticks.

In 1988, Unilever introduced the first one-step test, a sleek plastic stick that was simply exposed to "mid-stream" urine. A blue stripe slowly appeared to indicate pregnancy (19). In 2003, battery-operated devices were introduced, and some replaced the thin blue line with a digital readout (3).

Digital electronics allowed designers to become more creative. They proposed a variety of cutesy, cheery images (such as a baby's smiling face, a swollen belly, or even a single wriggling sperm) that would appear in a small display window to indicate pregnancy (4). But as Marcel Wanders, a product designer, warned, "You can't put too much meaning into it" because for some women the news was neither cheery nor cute (4). Ultimately, designers settled for unpretentious indicators, such as the colored stripe or a simple digital message: "pregnant" or "not pregnant" (3).

Eco-friendly Privacy

The largest distributors of home pregnancy kits have always been drugstores and pharmacies. But many manufacturers are now focusing on online marketing, which not only is more convenient for customers but also provides another layer of privacy.

In December 2017, the FDA approved "Lia," an even more empowering innovation in product design. Lia contains no glass fibers, plastic, electronics, or batteries. The special paper construction (similar to multi-ply toilet paper) is the first flushable and biodegradable pregnancy test. The inventors, echoing Margaret Crane's perspective, said that they specifically created Lia "for women who value privacy, empowering users to choose how to share their results" (21, 22).

The global market for home pregnancy and fertility tests is currently valued at \$1 billion and continues to grow. Over half of those sales are in North America, where one-third of all women have used a home pregnancy test (19). It is estimated that 80% of American women now learn they are pregnant from a kit they purchased and used themselves (17).

Witnessing the phenomenal success of the home pregnancy test, Meg Crane thought that its humble beginnings should be preserved. She dug through her closet and retrieved her original prototype, along with one of the original Canadian commercial products and accompanying advertising copy that she and Sturtevant had devised.

In June 2015, Bonhams in New York auctioned the collection as Lot 37. The most prized item in the lot was the little plastic prototype that Crane had patented (1, 17). The Smithsonian outbid everyone else, offering \$2000 over the pre-sale estimate. The historic object now resides at The National Museum of American History (2).

Looking back on the evolution of her idea, from paperclip container to biodegradable dipsticks, Margaret Crane could not be happier. "People come up to me, women and a surprising number of men, to thank me," she says. "I'm very pleased about that" (17).



The Pharmacologist,
Volume 60,
Number 2,
June 2018

References

- Bonhams (2015) Lot 37, Original Predictor home pregnancy test prototype, 1968; available from: <http://www.bonhams.com/auctions/22407/lot/37/>
- Catlin R (September 21, 2015) The unknown designer of the first home pregnancy test is finally getting her due. *Smithsonian.com*; available from: <https://www.smithsonianmag.com/smithsonian-institution/unknown-designer-first-home-pregnancy-test-getting-her-due-180956684/>
- Leavitt S A (December 2003) A thin blue line: The history of the pregnancy test kit. Office of NIH History; available from: <https://history.nih.gov/exhibits/thinblueline/introduction.html>
- Romm C (June 17, 2015) Before there were home pregnancy tests. *The Atlantic*; available from: <https://www.theatlantic.com/health/archive/2015/06/history-home-pregnancy-test/396077/>
- Yong E (May 4, 2017) How a frog became the first mainstream pregnancy test. *The Atlantic*; available from: <https://www.theatlantic.com/science/archive/2017/05/how-a-frog-became-the-first-mainstream-pregnancy-test/525285/>
- Gurdon JB and Hopwood N (2000) The introduction of *Xenopus laevis* into developmental biology: of empire, pregnancy testing and ribosomal genes. *Int J Dev Biol* **44**: 43-50.
- Friedman MH (1976) The development of the rabbit test for pregnancy. *Am J Obstet Gynecol* **126**(6): 728-729.
- Howe M (March 10, 1991) Dr. Maurice Friedman, 87, dies; created rabbit pregnancy test. *New York Times*; available from: <http://www.nytimes.com/1991/03/10/obituaries/dr-maurice-friedman-87-dies-created-rabbit-pregnancy-test.html>
- Friedman MH (1939) The assay of gonadotropic extracts in the post-partum rabbit. *Endocrinology* **24**(5): 617-625.
- Friedman MH (1932) On the mechanism of ovulation in the rabbit. IV. Quantitative observations on the action of extracts of urine of pregnancy. *J Pharmacol Exp Ther* **45**(1): 7-18.
- Spielman F (1934) The Friedman pregnancy test. *Am J Obstet Gynecol* **27**(3): 448-450.
- Crew F A E (1939) Biological pregnancy diagnosis tests: A comparison of the rabbit, the mouse, and the "clawed toad" (*Xenopus laevis*) as the experimental animal. *BMJ* **1**(4084): 766-770.
- Wide L and Gemzell CA (1960) An immunological pregnancy test. *Acta Endocrinologica* **35**: 261-267.
- Midgley AR (1966) Radioimmunoassay: A method for human chorionic gonadotropin and human luteinizing hormone. *Endocrinology* **79**(1): 10-18.
- Vaitukaitis JL, Braunstein GD, and Ross GT (1972) A radioimmunoassay which specifically measures human chorionic gonadotropin in the presence of human luteinizing hormone. *Am J Obstet Gynecol* **113**(6): 751-758.
- Digest (1979) Home pregnancy test simple to use, reasonably accurate, especially if result is positive. *Family Planning Perspectives* **11**(3): 190-191.
- Kennedy P (July 31, 2016) The pregnancy test scandal. *New York Times*; available from: <https://www.nytimes.com/2016/07/31/opinion/sunday/could-women-be-trusted-with-their-own-pregnancy-tests.html>
- Crane MM (May 18, 1971) Diagnostic test device. US Patent 3,579,306.
- Kennedy P (July 29, 2012) Who made that home pregnancy test? *New York Times Magazine*; available from: <http://www.nytimes.com/2012/07/29/magazine/who-made-that-home-pregnancy-test.html>
- Entwistle PA (1976) Do-it-yourself pregnancy tests: the tip of the iceberg? *Am J Pub Health* **66**(11): 1108-1109; available from: <https://www.ncbi.nlm.nih.gov/pmc/articles/PMC1653504/>
- Duffy S (December 5, 2017) First flushable pregnancy test cleared for OTC use. *MPR*; available from: <http://www.empr.com/news/pregnancy-test-lia-biodegradable-flushable/article/712019/>
- Gibbs C (December 11, 2017) Flushable pregnancy test receives FDA clearance. *New York Daily News*; available from: <http://www.nydailynews.com/life-style/flushable-pregnancy-test-receives-fda-approval-article-1.3691585>



THE EXTRAORDINARY PERCY JULIAN

Rebecca J. Anderson, PhD

© United States Postal Service. All rights reserved.

Percy Lavon Julian postage stamp, 1993, USPS Black Heritage® Stamps.

On April 23, 1999, the American Chemical Society presented a plaque to DePauw University, designating the institution's science center as a National Historic Chemical Landmark. The plaque recognized the pioneering research of Percy Julian, who "made physostigmine readily available for the treatment of glaucoma" (1).

Today, much better drugs are available for glaucoma patients, and physostigmine is mostly

a historical footnote. But in the 1930s, this was a major scientific achievement. It also marked the beginning of Julian's extraordinary career. No matter how challenging the problem in his personal or professional life, Percy Julian always succeeded. He had inherited academic prowess from his father and, as a child, learned one guiding principle from his grandfather: "There is always a way" (2).

Worth the Scars

Percy Julian was born in Montgomery, Alabama in 1899, the oldest of 6 children and the grandson of slaves (2). His father, James Julian, was a railway mail clerk (2, 3). Because of James's status as a federal employee, the family ranked higher than most African-Americans at that time, but public libraries in the South were closed to them. So, James amassed an extensive home library, and he studied mathematics and philosophy. He also impressed on all of his children the importance of formal education (2, 4).

Public education for Southern African-American students

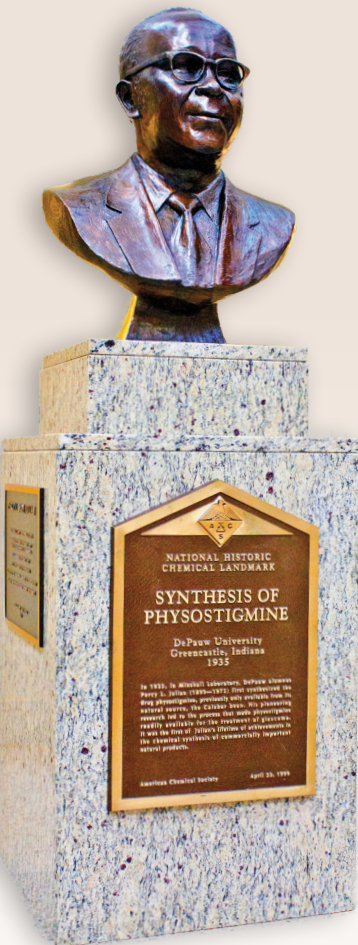

Copyright held by DePauw University.

National Historic Chemical Landmarks dedication, 1999, DePauw University, Greencastle, Indiana.

ended at the eighth grade. Two additional years of training were available for African-American teachers. In 1916, Percy graduated from the State Normal School for Negroes, the teacher training school in Montgomery (3). Then, he was accepted at DePauw University in Greencastle, Indiana.

On a warm fall day, the entire Julian family stood on the railway platform to say goodbye to the teenager who embodied their hopes and dreams. Percy's grandmother had once picked a record 350 pounds of cotton in one day (3). His grandfather was missing 2 fingers, cut off a half-century earlier as punishment for learning to read and write (3, 5).

Percy was among several African-American students at DePauw, but the college dormitories were not open to them (4). He struck a deal with the Sigma Chi fraternity. In exchange for board and a bed in the basement, he worked as a waiter in the fraternity's dining hall (2-4). To help pay his tuition, Percy also worked as a ditch digger (2, 4).



Percy Lavon Julian, chemist.

On his first day of class, a white student reached out his hand and said, "How are you—Welcome!" Julian had never shaken hands with a white person and wondered whether or not he should. "But," he later recalled, "in the shake of a hand my whole life changed. I soon learned to smile and act like I believed they all liked me, whether they wanted to or not" (2).

Julian was classified as a "sub-freshman" at DePauw. During his first two years, he took classes at a nearby high school to earn his diploma, in addition to his regular college courses (1, 4). He soon caught up and majored in chemistry. The department was headed by William M. Blanchard, the first person DePauw had hired with a PhD in chemistry (1).

In 1920, Julian graduated as valedictorian of his class (1-4). At commencement, his great-grandmother showed Percy for the first time the deep scars she had received from a beating during the last days of the Civil War. She proudly held his Phi Beta Kappa key and said, "This is worth all the scars" (4).

During this time, James Julian moved his family to Greencastle, and Percy's two brothers and three sisters also subsequently graduated from DePauw (2, 6).



Dean William Martin Blanchard, DePauw University.

Going Places

Percy wanted to continue studying chemistry in graduate school, but everyone tried to dissuade him. His father urged him to study medicine. In those days, the only African-American families that enjoyed near-middle class status were those whose breadwinner worked as a physician, undertaker, or federal employee, and in fact, Percy's two brothers eventually became physicians. To James, a chemist was no different than being a teacher, and "that in totality means you're going to starve to death" (3). He was all too familiar with the plight of lowly-paid teachers at African-American schools.

Likewise, Percy's professors discouraged him. Certainly, they were impressed with his undergraduate performance and had written letters of recommendation on his behalf to all the top graduate school programs in chemistry. Even his classmates assumed that he would receive a plum acceptance (3).

But the response was disappointing. Blanchard showed him a sampling of the replies, which expressed concern that, as an African-American man with a PhD, Percy would be overqualified (3, 4). One admitted, "We couldn't get him a job when he's done, and it'll only mean frustration. Why don't you find him a teaching job at a Negro college in the South? He doesn't need a Ph.D. for that" (6).

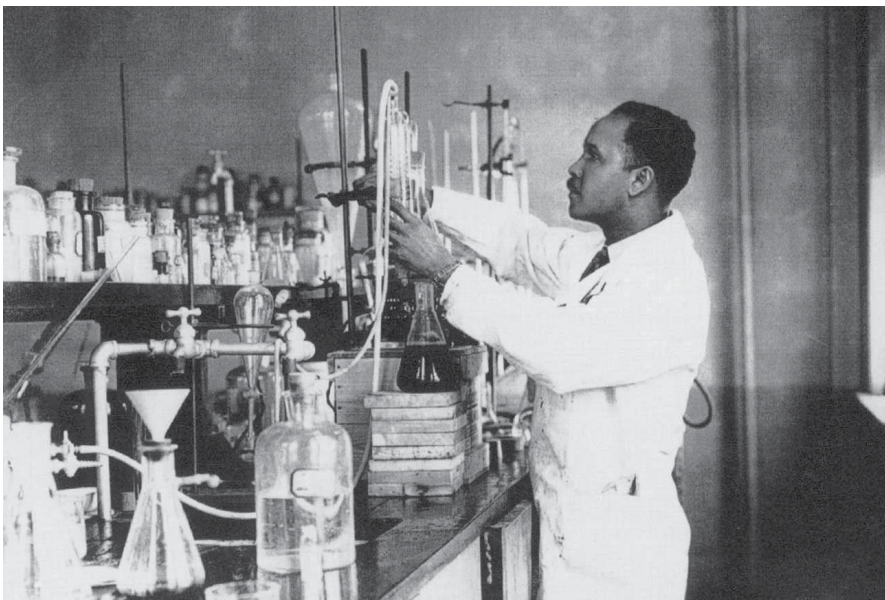

Chemist Percy Julian in his lab at DePauw University.

Julian chafed at the limitations imposed on him, but he made the best of his situation (4). He took a position as a chemistry instructor at Fisk University in Nashville and wrote a completely new set of lectures for the organic chemistry course (1, 4). William Blanchard, at DePauw, was so impressed with the lectures that he recommended Julian for the Austin Fellowship in chemistry at Harvard (4).

Julian arrived in Cambridge, Massachusetts, in 1922 and earned his master's degree in chemistry the following year (2, 4). While still a student, he began his lifelong advocacy for civil rights. He was in demand on campus as a speaker on social justice issues (3).

Julian remained at Harvard for three more years with the aid of minor fellowships, working as a lab assistant and studying biophysics and organic chemistry (3). But he was denied a teaching assistantship, an essential part of the doctoral program. Harvard was concerned that Southern white students would be offended by having an African-American teacher (3, 4). For many years afterward, Harvard's decision festered in Julian's memory, but he expressed his disappointment and anger only to his closest friends (2).

In 1926, Julian accepted a position as professor—and the only chemistry faculty member—at West Virginia State College, which at that time was an all-black institution (1-3). It was an era when pharmacologists were finding medicinal uses for plant alkaloids. And organic chemists sought to extract and identify those alkaloids and then synthesize them *de novo*.

Ernst Späth, a world-famous natural product chemist in Austria, was the first to synthesize

mescaline and one of the first to synthesize cuscohygrine, an alkaloid found in coca (2). In West Virginia, Julian re-created Späth's methods for synthesizing nicotine and ephedrine (4).

Julian's work won him the notice of Howard University, the nation's most prominent African-American university. In 1928, he was appointed associate professor and head of Howard's chemistry department (3, 4).

At Howard, Julian worked long hours, serving as everything from teacher and administrator to glass washer, stockroom clerk, and janitor (3, 4). He was a brilliant and magnetic lecturer, and his enthusiasm was infectious to colleagues and students alike (3).

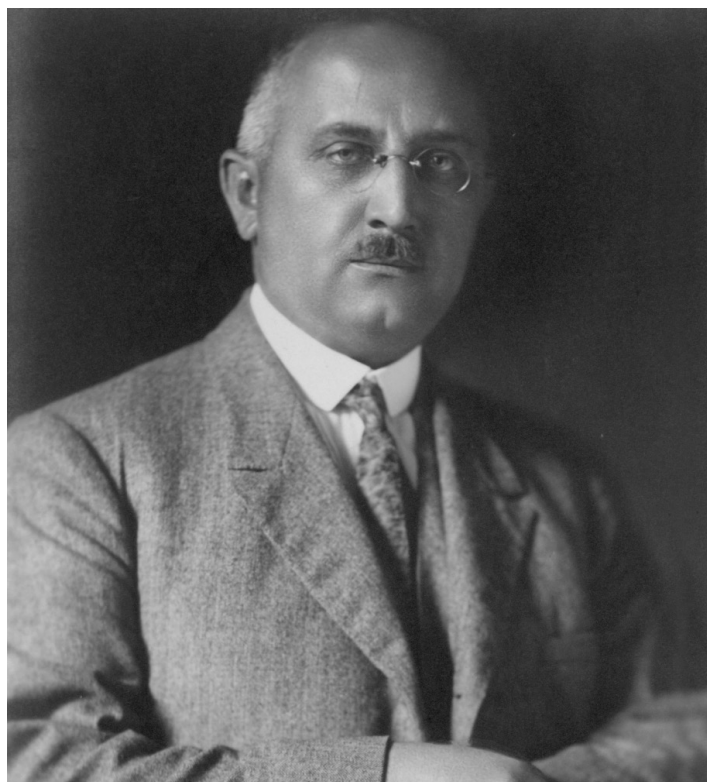

Reprinted with permission from the Archive of the University of Vienna (Photographer: Theo Bauer)

Austrian chemist Ernst Späth, doctoral advisor to Percy Julian at the University of Vienna.

His greatest passion, though, was research (4). He constantly discussed research problems. Any student who happened by his lab at the end of the day would likely be invited to Julian's home, along with one or two associates. They would discuss chemistry while they prepared dinner, as well as during and after the meal, in the "warm company of a genial host" (3).

Waltzing through Vienna

In 1929, Julian came to the attention of the head of the Rockefeller Foundation, who was impressed with his ability and character (3, 4). Rockefeller awarded

Julian a General Education Board Fellowship (3). The grant allowed Julian, finally, to pursue his doctoral studies, and he elected to study under Späth at the University of Vienna (1-3). Späth's lab at Vienna's prestigious Chemische Institut was an internationally acclaimed center for natural products chemistry (2, 4).

In Vienna—for the first time in his life—Julian encountered no barriers and felt completely at ease (2, 4). He had access to all levels of society, and he took full advantage of it. He skied in the Rax Mountains, swam in the Danube, played tennis, and attended the opera. He took lessons to sharpen his piano skills and played spirituals and the classics with equal skill. He also learned to speak impeccable German (2, 4).

Julian's fellowship allowed him to purchase crates of glassware and lab equipment that were out of reach for the average graduate student in impoverished, post-World War I Austria (2). Those supplies, along with Julian's good humor and friendly personality, quickly won over his new colleagues. All of Späth's other 15 graduate students were his friends. Julian frequently entertained them at his elegant apartment, which was just a short walk from Späth's lab (2).

The Viennese graduate students were impressed with Julian's passion for hard work, profound chemical knowledge, and astounding memory. He was particularly noted for his neatness, clean work bench, and contagious, uninhibited laughter (2). Even Späth, a critical and implacable professor, called Julian "an extraordinary student, the like I have not seen before in my career as a teacher" (2).

For his PhD thesis, Julian isolated and identified a medicinal alkaloid found in *Corydalis cava*, a plant that grew in the Vienna woods (2, 5). This work formed the foundation for his later research on an extensive series of plant-derived alkaloids.

In September 1931, Julian received his PhD from the University of Vienna and sailed back to the US on the *Queen Elizabeth* (2). He had bloomed into a dapper, self-assured man of the world (4). Accompanying him was Josef Pikel, a Viennese friend and fellow graduate student.

When they arrived at Howard University, Julian was promoted to full professor and laid plans to build a new chemical research center (3, 4). Julian vowed to "give every damned ounce of my energy towards...as much research as the day's hours and my strength will allow" (4).

Unfortunately, he soon became embroiled in controversy (3). He brashly involved himself in campus politics, and a scandal surrounding his personal

life erupted when some of his private letters were published in the local paper. While a graduate student, he had written frequently to friends and colleagues, embellishing his experiences in Vienna. In particular, he had bragged about the charms of Viennese women, with whom he had attended the opera and stayed out late drinking wine (4). He resigned his position at Howard in 1932 (3).

William Blanchard, who had become Dean of Liberal Arts at DePauw University, offered Julian a position as a research fellow, along with teaching responsibilities (1-4). With Blanchard's backing, Julian replaced DePauw's usual senior courses in qualitative organic analysis, organic synthesis, identification of organic compounds, and literature studies with an amalgamated combination of these courses in the form of fundamental research problems (2).

Every student who qualified to receive a research problem performed brilliantly. Over the next 4 years, 30 impressive senior theses resulted, 11 of which led to publications in the *Journal of the American Chemical Society* (2). Most of those papers read more like doctoral dissertations than senior theses.

The DePauw fellowship was a big step down from Julian's professorship at Howard and paid considerably less, but he could continue his research (4). Josef Piki had followed him to DePauw, and together they pursued a vigorous program synthesizing plant alkaloids (2). Their first project aimed high: the synthesis of physostigmine.

Breakthrough and Setbacks

In 1864, Julius Jobst and Oswald Hesse had isolated physostigmine, the main alkaloid found in the Calabar bean (2, 7). Physostigmine is a reversible acetylcholinesterase inhibitor, promotes drainage of aqueous humor from the eye, and decreases intraocular pressure. In the 1930s, physostigmine was the preferred treatment for glaucoma (4). But extracting physostigmine from Calabar beans was tedious and expensive.

Chemical synthesis might provide a viable alternative, and several research groups tackled this very challenging project. Among them was Sir Robert Robinson, a world-

famous researcher and leader in synthetic organic chemistry at Oxford University (5).

In 1932, Robinson published the last of a series of 10 papers in which he claimed to have synthesized d,l-eserethole, a critical alkaloid intermediate and one step from the final product, physostigmine (2, 5). Julian and Piki had followed a different synthetic path, relying on simple, inexpensive starting materials to make this molecule (5). Robinson and Julian gave their molecules the same name, but the two compounds had very different properties. Julian was confident that his synthesis had produced the correct molecule.

DePauw lacked the prestige of institutions like Oxford, and the young Julian was a virtual unknown compared to the eminent Robinson. Piki urged his friend to be cautious, fearing that challenging Robinson would stifle Julian's promising career and ruin his reputation, if he was wrong (2). Instead, a headstrong and confident Julian insisted on publishing.



Calabar plant.

Julian and Piki's paper pulled no punches: "We believe that the English authors are in error, that the compound they describe as d,l-eserethole is not the substance, and that we are describing for the first time the real d,l-eserethole" (8). Their detailed analytical data left no doubt who was correct.

Starting with phenacetin, Julian and Piki synthesized physostigmine in 11 elegant steps. The project took 3 years, and their 1935 paper, "The complete synthesis of physostigmine (eserine)," is considered a classic (1, 7).

Telegrams of congratulations arrived from around the world (2). Physostigmine became readily available for the treatment of glaucoma (1, 6). And the work established Julian's reputation as a world-class chemist. He was just 36.

After the grant funding Julian's position expired, Blanchard wanted to appoint Julian to the faculty, but despite his accomplishments, the DePauw Board of Trustees did not allow it (1, 3). He was also strongly recommended for a faculty position at the University of Minnesota, but the university's Board of Regents refused (3).

In frustration, Julian began applying for industry positions (1, 3). But time and again, he was turned away with apologies when the interviewer saw that he was African-American (4).

Finally, Harry Lewis, Dean of the Institute of Paper Chemistry in Appleton, Wisconsin, offered Julian a research staff position (2-4). Lewis had been impressed with several of Julian's DePauw students, who were in the Institute's doctoral program (2). Julian's professional credentials were impeccable, but Lewis and his colleagues struggled with how to accommodate him in Appleton. An old but still active city statute stated that "No Negro shall be bedded or boarded in Appleton overnight" (2)

"I'll Just Hire Him"

At DePauw, one of Julian's projects had involved isolation of another Calabar bean alkaloid, geneserin (2). He extracted oil from the bean, washed it with dilute acid, and then with water and set the flask aside. A few weeks later, he saw small glistening crystals in the liquid (1, 2). After recrystallization, he isolated a small amount of pure material. A literature search indicated that it was not geneserin, but rather a sterol, stigmasterol. (Stigmasterol contains a central steroidal unit of four fused rings that are common to steroids such as cholesterol and the sex hormones.)

Adolf Windaus and A. Hauth had first isolated stigmasterol in 1906 (2). About the same time, Erhard Fernholz and Adolf Butenandt published their first papers on steroid chemistry using stigmasterol as the starting material. Fernholz and Butenandt had extracted stigmasterol from soybean oil (2, 4).

The soybean had been gaining economic importance in the early 1930s. Henry Ford promoted its use for making automobile parts and lubricants. Glidden Company, a paint and varnish manufacturer, was also pursuing soy-based products.

To continue his stigmasterol experiments, Julian wrote to Glidden and requested five gallons of soybean oil. He was surprised when William J. O'Brien, the company's vice president, personally called and invited him to interview for a research position (2).

O'Brien was in Appleton attending a Board meeting of the Institute of Paper Chemistry. He listened while Dean Lewis and the Board deliberated over accommodations for Julian in Appleton. O'Brien thought, "If he is half as good as they say he is, I can use him at Glidden. I won't say anything about who he is; I'll just hire him" (2). O'Brien slipped out to telephone Julian.



Reprinted with permission from University of Oxford

Sir Robert Robinson, Nobel Laureate, and the Waynflete Professor of Chemistry (1930-1954) at Magdalen College in Oxford University.

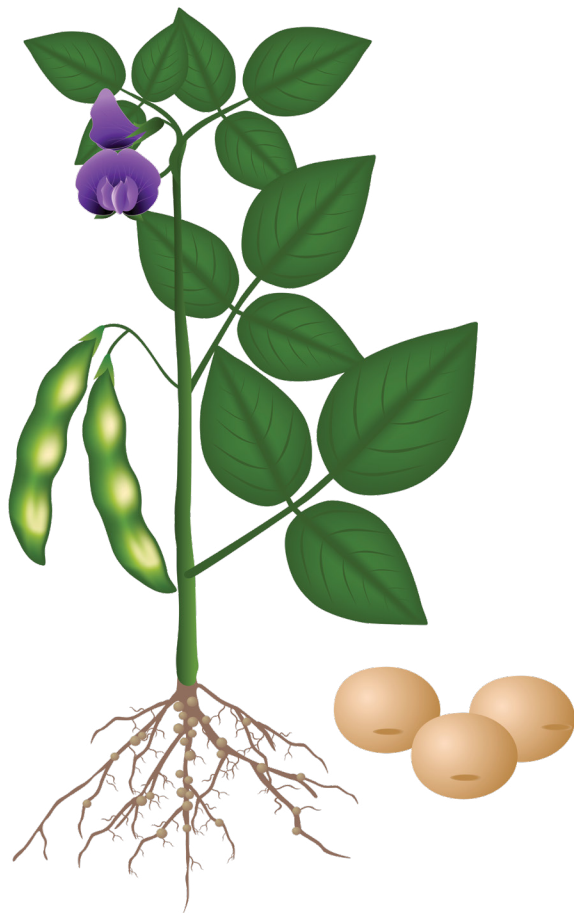

Soybean plant

Julian went to Chicago for the interview and was hired on the spot as director of research in Glidden's new Soya Products Division. His job was to devise profitable products from soybean extracts (2, 4).

When Julian arrived at Glidden in 1936, construction had begun on a new plant for large-scale processing of soybean oil. The German construction firm, Electro-Chemie, had been contracted to build the plant. Julian frequently consulted in German with the large contingent of visiting technicians. He was on-call around the clock and functioned as engineer, chemist, researcher, and salesman. When completed, Glidden's plant was the world's first industrial-scale facility for isolating and producing vegetable proteins (2).

Julian's first success was isolating soy "alpha-protein" (4). Alpha-protein is mainly used for paper coatings, in which it serves as a pigment binder. Julian then adjusted the size of the soy protein to suit a variety of other applications, including "latex" house paints.

Glidden, in conjunction with a Pennsylvania laboratory, also used alpha-protein to create a fire-retardant product called Aero-Foam (4, 5). The

foam could be packaged in canisters and sprayed like shaving cream. It was effective in extinguishing otherwise uncontrollable oil and gasoline fires, especially those occurring on aircraft carriers (5). The US Navy called it "bean soup," and it saved the lives of thousands of servicemen during World War II (4).

The US Navy called it "bean soup," and it saved the lives of thousands of servicemen during World War II.

The factory's output of 40 tons of soy protein per day made the Soya Products Division Glidden's most profitable unit (2). In parallel, Julian's lab developed other soy-based products, including cooking oils, shortenings, and lecithin for Glidden's Durkee foods division, as well as plastics, glues, and high-protein food for livestock and dogs (4).

Leading by Example

Virtually everyone who worked with Julian was amazed and inspired by his intellect and work ethic. Josef Piki said, "Percy generated ideas faster than half a dozen people could critically review and test them. He also did most of the writing [and] did practically all of the analytical work" (2).

At Glidden, Julian was a tireless task master with a strong temper. He spoke and carried himself with a European flair, supervising his workers in a white coat. But he was highly respected and many of his employees were extremely loyal. Some stayed with him for decades (4).

Edwin Meyer, a key assistant at Glidden, said, "He was obviously a man of great energy and ability who galvanized us all. There may have been resentments that related to his color, but we were never made aware of them. We were too busy working" (5).

Julian was not only the first African-American to direct a modern industrial laboratory; he also hired grateful black and female chemists when no one else would (3, 4). And he never hesitated to help those who had personal or financial problems (2).

Accidental Bonanza

By the time Julian had been at Glidden for 4 years, he had acquired a reputation as the Division's chief troubleshooter. One day, a panicked worker sought

his advice about a 100,000-gallon tank of purified soybean oil that had been contaminated. Water had seeped into the oil and a white solid had formed in the bottom of the tank (1, 2).

Julian remembered his experience at DePauw, where he had crystallized stigmasterol from Calabar bean oil after exposure to water. He realized that the leaked water had precipitated the trace amounts of sterols contained in soybean oil (1). He rushed to the site and instructed the workers to centrifuge the whole tank. The oily white mass contained about 15% mixed soya sterols. With dogged persistence, Julian adjusted the accidental water-precipitate procedure, and his optimized refining method was able to extract 100 pounds of mixed sterols daily (2).

At this time, Julian was research director of the Durkee Food Division and manager of Glidden's Fine Chemical Division, in addition to research director of the Soya Products Division. Despite his heavy administrative responsibilities, he remained personally involved in research, and now he added steroid chemistry as a personal project (2). He reassigned some of his employees to work on steroids—specifically intending to use stigmasterol to synthesize human sex hormones, progesterone in particular (4).

Like nearly one in six women at the time, his wife had suffered miscarriages. Progesterone could reduce the risk, but it was expensive and supplies were limited (4). Progesterone was extracted from animal urine, a very inefficient process. Julian knew that making progesterone from soybean oil precursors would be easier and less expensive.

Working 14-15 hours a day including weekends, Julian devised innovative methods and specialized equipment for synthesizing steroids—methods that were widely adopted. Glidden became the first American producer of bulk quantities of progesterone and other sex hormones (2). The price of progesterone dropped dramatically—still with a healthy profit for Glidden (1, 2, 5).

In the 1940s, steroid chemistry was an active field. Switching from animal to plant sources represented a major breakthrough, making chemical synthesis of medicinal steroids easier and the drugs more widely available to patients. Russell Marker, most notably, discovered that the Mexican yam was a richer source of steroid precursors. For the rest of the decade, Marker's Syntex plant in Mexico and Glidden in Chicago produced most of the world's supply of progesterone (4, 5).

Competing Cortisones

Also in the 1940s, Lewis Sarett at the Merck Laboratories was the first to synthesize cortisone (2, 9). In Switzerland, Tadeus Reichstein synthesized a steroid that he called Substance S, which, like cortisone, was a hormone found in the cortex of the adrenal gland. Substance S differed from cortisone only by lacking an oxygen molecule at position C11.

In 1948, Philip Hensch and Edward Kendall at the Mayo Clinic discovered that cortisone reversed the symptoms of rheumatoid arthritis (2, 9). The synthetic routes devised by Sarett and Reichstein were landmark achievements, but they required dozens of steps, and the yield was low. Sarett's method used ox bile as the starting material, and thousands of animals were needed to produce enough cortisone to treat a single patient for a year (4). Cortisone, therefore, remained expensive to produce and limited in supply.

On the heels of Hensch and Kendall's discovery, Julian published a new and more practical method for synthesizing Reichstein's Substance S. Instead of animal bile, he used soybean derivatives as the starting material (2, 5). But converting Substance S to cortisone using organic synthesis techniques was not trivial.

Within a few years, researchers at Upjohn developed a microbiological process using *Rhizopus nigricans*, which was the first economical method for converting Substance S into cortisone. This same microbe could also metabolize progesterone to produce cortisone—an even better method (4, 5).

Julian admitted that because of his intense interest in steroids, his other work was receiving “scant attention...a circumstance which I must remedy” (2). He proposed that Glidden stop making cortisone from soybean-derived Substance S and switch to the sterol-rich Mexican yam. The reduced production costs and improved efficiency would position Glidden as a mass producer of cortisone, as well as progesterone (4, 5). But Glidden said no.

Julian's steroid research had drifted far afield from Glidden's core product line of paints. The company was already taking steps to get out of the steroid business. When this Division was sold to Pfizer, Glidden asked Julian to teach his Compound S production process to the Pfizer chemists (4, 5).

Personal Dignity

Julian's successes brought both the appreciation of Glidden and sizeable increases in pay (3, 4). His patents made him a fortune (6). His many "firsts" in steroid chemistry had also greatly enhanced his reputation, even more than his synthesis of physostigmine. He was showered with awards and honorary degrees and named to the boards of dozens of universities (2).

In 1950, with his success well established, Julian purchased a home in Oak Park, an upscale suburb of Chicago, where Ernest Hemingway and Frank Lloyd Wright also owned homes (2). The Julians were the first African-American owners in the neighborhood, and on Thanksgiving, the night before they moved in, arsonists poured gasoline on the wooden floors and up the staircase of their house (3, 4). Fortunately, it failed to ignite. Not to be deterred, the Julians cleaned the floors and moved in (4).

In June 1951, dynamite was thrown from a speeding car and exploded beneath the bedroom window of the two Julian children (3, 4). Percy and his wife were in Baltimore attending the funeral of Percy's father. Fortunately, the children and their sitter were unharmed (3).

Following this incident, Percy and his son spent many nights sitting in a tree in their front yard, with a shotgun in hand. Percy junior sensed that his father was fighting angry, but Percy made it a teachable moment and calmly counseled his son about "how wrong and how stupid it was" (4).

Many Oak Park residents rallied to the Julians' defense. They published a letter in the *Sun Times*, denouncing violence (3, 4). "We ask Dr. Julian and his family to accept our sincere apology that such un-American and bigoted action should occur in our village. We welcome them to Oak Park and are honored that they should desire to live among us" (3).

Turning Entrepreneur

When Glidden divested its interest in steroids, Julian realized that if he wished to continue this line of research, he would have to do it on his own (4). After 18 years at Glidden, he resigned in 1953 and created Julian Laboratories in Oak Park (1-3). He retrofitted a dilapidated, rat-infested warehouse into a fully functioning manufacturing plant (4, 5).

In the first few years, Julian focused his attention on building the business, with little time for research, except

for the steroid intermediates he was producing for his clients (2). He landed contracts with Upjohn, Ciba, Pfizer, and Merck to produce progesterone from soybeans (4).

But to compete with Syntex, Julian needed Mexican yams and a facility in Mexico to process them. Banks were reluctant to make industrial loans to people of color (5). So, he built Laboratorios de Julian de Mexico, just outside Mexico City, using his own savings, along with the assistance of friends and private investors (3, 4).

After the factory was built, the Mexican government refused to grant Julian a permit to harvest yams in Mexico (4). Just at that moment, Julian received a visit from Abraham Zlotnik. They had been fellow students in Vienna, and later, Julian had helped Zlotnik escape Hitler's Germany (4, 5).

Zlotnik knew Central American geography and said he was certain the yams that Julian needed also grew in Guatemala. He volunteered to make an expedition on Julian's behalf, quickly found a steady supply of yams, and arranged to ship them to Julian (4, 5). Julian had already sunk all of his cash into the Mexican factory and said he didn't know when he could repay Zlotnik. Zlotnik replied, "You've already paid me back" (4).



Mexican yam, Smithsonian Gardens.

Reprinted with permission from Smithsonian Gardens (Photographer: Matt Fleming)

In 1956, the US Senate held public hearings, investigating allegations that Syntex had used its influence with the Mexican government to maintain a monopoly on Mexican yams. Julian's company was one of several that claimed damages, and he was a key Senate witness (4, 5). As a result of pressure on the Mexican government, yams became readily available to any buyer (5).

By 1957, Julian had established plantations in Guatemala and another processing plant, Empress Agro-Quimica Guatemaleca (2-4). Meanwhile, Julian's Oak Park chemists found a way to quadruple production of progesterone from yams. The breakthrough made Julian Laboratories one of the world's largest producers of drugs from yams (3, 4).

Julian could have garnered huge profits, but instead he dropped the progesterone price 10-fold, from \$4000 to \$400 per kilogram (4). He set the price so that "everyone who needs it may get it" (2).

The businessman in Julian wanted to make money, but when he negotiated with a buyer, he would often make an over-generous offer or concession. Later, he would tell his attorney, Benjamin Becker, "I don't mind making a profit, but I want them to make one too" (2). Still, he became a millionaire and one of the richest black men in America (4).

Julian's syntheses of progesterone and other steroids were acclaimed as outstanding achievements, but he also pursued research on vitamin D, tryptophan, and yohimbine (3, 6). He studied the metabolic pathways of vitamin D, and pre-vitamin D₃ was a major product sold by Julian Laboratories to vitamin manufacturers (3). He also synthesized alanine intermediates and elucidated the metabolic pathway for conversion of tryptophan to kynurenine (2, 3).

His facile synthesis of the yohimbine ring skeleton paved the way for complete synthesis of reserpine, a rauwolfia alkaloid and early antipsychotic drug (2, 3). His monograph on the "Chemistry of Indoles" in volume 3 of *Heterocyclic Compounds* (1952) is considered a classic reference for researchers in this field (2).

In 1961, Julian sold Julian Laboratories to Smith, Klein, and French for \$2,338,000 (\$20 million in today's currency), remaining as president at a generous salary (1, 3, 5, 6). At the same time, Upjohn purchased the Guatemala factory (3).

In 1964, Julian founded and focused his efforts on two new enterprises in Franklin Park, Illinois. He became president of Julian Associates, Inc., and director of the nonprofit research organization, Julian Research Institute (1-3).

A Man of Stature

Percy Julian exemplified the American dream, going from obscurity to astounding business success. But he was also a humanitarian and claimed a wide circle of friends. One said, "His wit and charm and grace made him one of the most 'clubbable' persons it has ever been my pleasure to know. He very much cherished the company of others, and others cherished his company even more, if such was possible" (2).

Rather than being bitter about the numerous barriers he faced, Julian championed human rights (1, 3, 4). He delivered and published countless addresses on the advancement of blacks in America, fair housing, and related civil rights issues. He also raised funds for the NAACP Legal Defense and Education Fund and participated in dozens of civic societies (3, 4).

When Martin Luther King, Jr. was killed in 1968, Julian (as a trustee of Howard University) patiently negotiated with students who had occupied Howard's Administration Building. He had personally suffered more from racism than any of them, but he knew their actions were wrong. He gave them the benefit of his wisdom and persuaded them to leave peacefully (3).

For decades, Bernard Witkop, a lifelong friend going back to Julian's days in Austria, lobbied his colleagues to admit Julian into the National Academy of Sciences (4, 5). Julian was finally elected to the Academy in 1973.

In 1974, Julian began undergoing treatment for liver cancer. Although his family tried to restrict his activities, he continued to head Julian Associates and the Julian Research Institute (5, 6). He also served as a consultant to major pharmaceutical companies (1, 4). Until his last days in 1975, he never looked back. He constantly talked chemistry and was full of plans (2, 3). "I have had one goal in my life," he said, "that of playing some role in making life a little easier for the persons who come after me" (6).

In 1990, Julian was posthumously inducted into the National Inventors Hall of Fame (4). In 1999, coinciding with the 100th anniversary of Percy Julian's birth, the American Chemical Society designated DePauw University as a National Historic Chemical Landmark. In addition to his pioneering synthesis of physostigmine, the Society recognized "Julian's lifetime of achievements in chemical synthesis of commercially important natural products" (1). But to those who knew him, he was fondly remembered as a mentor, humanitarian, and "the man who wouldn't give up" (2, 4).

But to those who knew him, he was fondly remembered as a mentor, humanitarian, and "the man who wouldn't give up."

For more about Percy Julian's life and work, see the PBS NOVA documentary, *Percy Julian: Forgotten Genius*; available from: <https://binged.it/2Kr8USp>.

References

1. American Chemical Society (1999) *Synthesis of Physostigmine: National Historic Chemical Landmark, DePauw University*; available from: <https://www.acs.org/content/acs/en/education/whatischemistry/landmarks/julian.html>
2. Witkop B (1980) Percy Lavon Julian, 1899-1975, *Natl Acad Sci Biographical Memoirs* **52**: 1-46; available from: <http://www.nasonline.org/publications/biographical-memoirs/memoir-pdfs/julian-percy.pdf>
3. Cobb W M (1971) Medical History: Percy Lavon Julian, PhD, ScD, LLD, LHD, 1899-. *J Natl Med Assoc* **63(2)**: 143-150.
4. Alexander U (June 25, 2007) Percy Julian, Chemist Extraordinaire. *Shunya's Notes*; available from: http://blog.shunya.net/shunyas_blog/2007/06/percy-julian-ch.html
5. Rooke T (2012) *The Quest for Cortisone*. Michigan State University Press, East Lansing, MI.
6. Bims H (March 1975) Percy L. Julian's fight for his life. *Ebony*, pp. 94-104.
7. Julian P L and Pkil J (1935) Studies in the indole series. V. The complete synthesis of physostigmine (eserine). *J Am Chem Soc* **57(4)**: 755-757.
8. Julian P L and Pkil J (1935) Studies in the indole series. IV. The synthesis of d,l-eserethole. *J Am Chem Soc* **57(3)**: 563-566.
9. Anderson R J (2016) Cortisone: A miracle with flaws. *Pharmacologist* **58(4)**: 199-210.

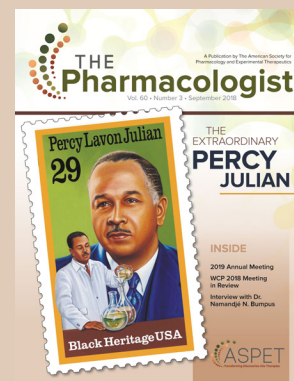

The Pharmacologist,
Volume 60,
Number 3,
September 2018

Rapamycin: The Fountain of Youth?

Rebecca J. Anderson, PhD

Sometimes the greatest discoveries come when you're looking for something else. Such was the case for Georges N6gr6dy. When he signed up for an expedition to Easter Island, the furthest thing from his mind was finding the Fountain of Youth.

N6gr6dy's colleague, Stanley Skoryna, a professor at McGill University, led the expedition, which was sponsored by UNESCO's International Biology Program and the Canadian government (1-3). Under the United Nation's umbrella of human adaptability research, Skoryna had devised a comprehensive study of the factors (climate, geology, genetics, and endemic diseases) that affect human health (1, 2).

Easter Island was the ideal study site. Known primarily for its massive *moai* statues, Easter Island in the mid-twentieth century was considered the "loneliest place on Earth" (1, 3). The island's inhabitants comprised the world's most remote community, residing 1,400 miles from the nearest port in an "empty" part of the Pacific Ocean. Their only connection with the rest of the world was an annual visit by a Chilean supply ship (1, 4, 5). Scientifically, Easter Island represented a self-contained biosphere in dynamic equilibrium—for Skoryna, a living laboratory (1, 3).

His multinational team of 38 physicians, scientists, and support staff landed on Easter Island on December 13, 1964. Over the next 2 months, they conducted comprehensive physical exams, blood tests, and X-rays on all 949 islanders (1-3). They also collected data on the islanders' diet, lifestyle, genealogy, and work habits, as well as samples of all the flora and fauna on the island and in the surrounding waters.

Easter Island

Georges Nógrády, a microbiologist at the University of Montreal, was among the most active and energetic members of the expedition (2). He collected 5,600 clinical specimens from the islanders to analyze for tetanus, tuberculosis, whooping cough, leprosy, and fungal diseases (2, 4).

In his spare time, Nógrády assisted the expedition's veterinarians, who were interested in the health status of the island's large population of sheep, horses, and cattle. He analyzed nearly 2,000 specimens for common livestock diseases (2).

The islanders should have been at high risk for tetanus. Horses outnumbered people on the island, and many islanders went barefoot (2, 5). Tetanus spores should have been easily transmitted, but there was no evidence of lockjaw (2). To investigate why, Nógrády divided the island into 67 one-mile squares and collected a core soil sample from the center of each square (2, 5).

When he returned to Canada in March 1965, Nógrády sent his soil samples to Louis Smith in Virginia for analysis (4, 6). Smith found tetanus in only one sample (5, 6). Satisfied that tetanus was almost entirely absent on Easter Island, Nógrády put the samples in frozen storage (4, 6).



Dr. Surendra Sehgal

Reprinted with permission from the Sehgal Family.

Dirt to Drug

In 1969, Nógrády donated his sample collection to Ayerst Pharmaceuticals in Montreal (5, 7). The microbiology team at Ayerst, headed by Surendra Sehgal, systematically isolated microorganisms from the soil samples and grew them in culture. Then, they extracted the chemicals produced by those organisms and tested each one for pharmacological activity.

One organism, *Streptomyces hygroscopicus*, produced a compound that could kill fungi (1, 5, 7). In 1972, Sehgal elucidated the compound's chemical structure (4, 8). He called it rapamycin, after Rapa Nui, the natives' name for Easter Island (4, 9). Unfortunately, the compound also suppressed the immune system, an undesirable property for an antifungal agent (9).

Sehgal had also sent the compound to the National Cancer Institute (NCI) for evaluation in its drug screening program. Rapamycin had "fantastic activity" against solid tumors (8, 9). According to Sehgal, "We had the notion we were dealing with something novel" (9). NCI designated it a priority drug and wanted to study it further, but Ayerst did not (4, 8, 9).

Sehgal elucidated the compound's chemical structure. He called it rapamycin, after Rapa Nui, the natives' name for Easter Island.

In 1983, to ease its financial burden, Ayerst decided to close its Canadian operations, which included the company's natural products division (4, 5, 8). Before the large-scale fermenters were shut down, Sehgal prepared one final batch of *S. hygroscopicus* (5, 8). He packed the bacterium into some vials and stuck them in the family's freezer. The package (next to the ice cream) was labeled, "DON'T EAT!" (5).



Streptomyces hygroscopicus

Reprinted under CC-BY-SA

Sehgal was among about 30 Montreal scientists who remained with Ayerst (5). When he relocated to the company's laboratories in Princeton, New Jersey, his son, Ajai, came home from college to help the family move. Ajai's job was to stuff the freezer (containing the vials) with dry ice and seal it with duct tape "so that the movers wouldn't open it" (5). The vials of bacteria stayed in the Sehgal family freezer in New Jersey for the next 5 years.

In 1987, Ayerst merged with Wyeth, and a new management team took charge of Wyeth-Ayerst Laboratories (5, 8, 9). Thinking his new bosses might be receptive, Sehgal wrote a memo proposing to restart rapamycin research. Of rapamycin's biological effects, the management team was most intrigued by its immunosuppressant properties (5, 9).

In 1983, Sandoz's cyclosporin A had been approved to prevent organ rejection in transplant patients, and that facilitated expansion of organ transplant procedures (5). Cyclosporin's success and impressive sales also stimulated the search for stronger immunosuppressant drugs (4).

Researchers at Fujisawa Pharmaceutical Co. discovered FK 506, another immunosuppressant compound. Interestingly, half of its chemical structure was identical to rapamycin (5, 10). Wyeth-Ayerst's management told Sehgal to contact outside investigators who could test rapamycin in animal models of organ transplant (5, 8).

This led to Wyeth-Ayerst's fast-tracked clinical trials. The Food and Drug Administration (FDA) approved rapamycin (Rapamune®) in 1999 for prevention of organ transplant rejection, and approvals around the world soon followed (4, 5, 8). Wyeth-Ayerst also licensed Rapamune to Johnson & Johnson for coating stents to prevent arterial blockage due to restenosis in heart patients (8, 11).

Rapalogs, Too

In parallel with the clinical trials, Sehgal contacted NCI, and the anticancer research on rapamycin resumed after a 6-year hiatus. NCI's interest remained high. According to Janet Dancey, a senior clinical investigator at NCI, "It didn't really look like any other drug in the cell line screen. Its pattern of activity was unique" (9). At that time, all chemotherapy agents were cytotoxic. Rapamycin was cytostatic (9).

Because the original rapamycin patent expired in 1992, Wyeth-Ayerst researchers conducted structure-activity studies to find an active analog that would be proprietary (5). They synthesized and tested hundreds of compounds. The best one was CCI-779 (temsirolimus). It was active against a wide variety of tumor types (9). The FDA approved temsirolimus (Torisel®) for treating kidney cancer in 2007 (5, 11).

Chemists at Novartis used a similar structure-activity strategy to create everolimus (Afinitor®), which was approved for advanced kidney cancer in 2009 (5). These "rapalogs" were subsequently approved for other cancers. Everolimus is also used in transplant patients. Other rapalogs are being developed as cancer drugs or for drug-eluting stents (5).

Monotherapy with rapamycin or rapalogs has been only modestly successful against cancer because they result in stable disease (i.e., cytostatic) rather

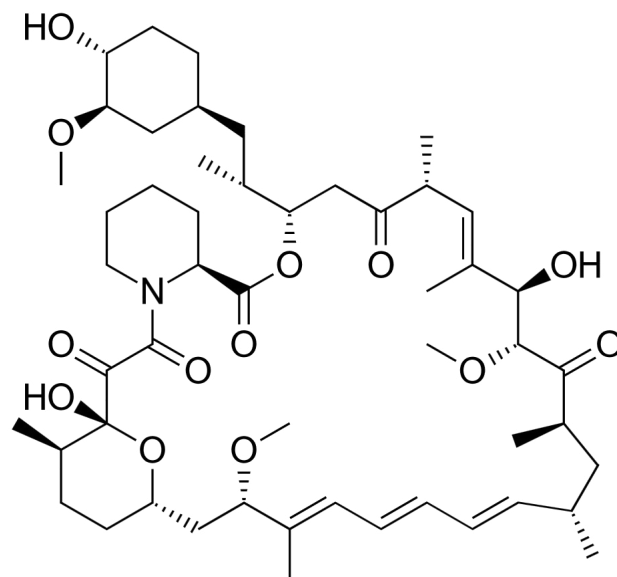

Skeletal formula of sirolimus (brand name Rapamune) — an mTOR inhibitor.

In the public domain

than tumor regression (12). Combining rapalogs with other anticancer agents seems to give better results. Several combos (e.g., with paclitaxel, carboplatin, or doxorubicin) have yielded additive or synergistic effects (12).

The New sTORy

In 1996, rapamycin pharmacology shot in a completely new direction, thanks to Michael Hall. After completing his postdoctoral work at UC San Francisco in the

late 1980s, Hall became an assistant professor at the Biozentrum of the University of Basel, Switzerland (13). He was studying how proteins are transported across the cell's nuclear membrane—a process that at the time was a black box—and the work was not going well (13).

Among Hall's collaborators was Rao Movva, group leader at Sandoz in Basel. Movva was interested in determining the mechanism of Sandoz's blockbuster new drug, cyclosporin A (13). Little was known about how cyclosporin A and FK 506 worked, except that they blocked import of something—perhaps a protein—into the nucleus of T-cells (13, 14). Because his own studies were going nowhere, Hall was willing to use Movva's drug as a tool to probe cell signaling pathways (13).

Hall chose a simple organism (baker's yeast) as his model system—an unusual choice for studying drugs that were destined for use in people. According to Hall, "Some viewed these experiments as tantamount to giving aspirin to yeast—why would we do something so physiologically irrelevant?" (13).

Hall chose a simple organism (baker's yeast) as his model system—an unusual choice for studying drugs that were destined for use in people.

His first experiments only seemed to justify the critics' skepticism. Cyclosporin A and FK 506 had little effect on the yeast cells (13). Then, Movva told Hall about rapamycin, a brand-new FK 506-lookalike. Rapamycin had not yet been approved and was not commercially available, but fortunately, Sandoz was one of the few places in the world that could provide it. Hall found that rapamycin blocked proliferation of yeast cells (13).

Using various yeast mutants, Hall's group soon isolated and characterized two genes, which they called TOR1 and TOR2 (for "target of rapamycin"). Those genes

encoded a couple of closely related proteins, and further experiments confirmed that the TOR1 and TOR2 proteins were inhibited by rapamycin (13). Hall and his postdoctoral fellow, Joseph Heitman, published these results in 1991 (14).

Subsequently, TOR, the first in a new family of kinases, was also found in other invertebrates, including nematode worms (*C. elegans*) and fruit flies (*Drosophila*). Using mice, other research groups found a mammalian molecule that resembled the invertebrate TOR (13, 14). This was subsequently named mTOR (for "mammalian" or "mechanistic" TOR).

By 1994, it was clear that TOR was highly conserved and that it performed similar tasks across the evolutionary spectrum. But the physiological role of TOR remained unknown (13, 14).



Michael N. Hall

Reprinted with permission from Biozentrum, University of Basel

A New Paradigm

At first, Hall thought that TOR controlled cell division because rapamycin had prevented his yeast cells from proliferating (13). But in subsequent experiments, Hall showed that when TOR is not functioning, yeast cells generate unusually small quantities of protein. The yeast failed to duplicate—not because nonfunctional TOR disrupted a specific job in cell division, but rather because protein manufacture plummeted in general, including the proteins involved in cell division (14). Without TOR, cells behave as if they are starving.

Without TOR, cells behave as if they are starving.

Conventional wisdom at the time asserted that cell growth was a spontaneous process (13). If raw materials such as amino acids and fatty acids were present, the cells would automatically manufacture the corresponding proteins and lipids. A growth regulator was not necessary (14).

However, in an elegant series of experiments in yeast, Hall's team demonstrated that cell growth is, indeed, an actively controlled process, and that TOR is the controller. When nutrients are scarce, yeast cells scale down production of proteins and most mRNA; they remain alive but metabolically dormant (13). Hall proposed that TOR's role is to stimulate cell growth when the appropriate nutrients are available (13, 14). This jarring new paradigm—that cell growth, as well as cell division, is a regulated process—was published in 1996.

Hall's discovery led to an explosion of work by many investigators who confirmed and expanded Hall's findings (13). They reported that TOR responds not only to nutrients but also to the presence of growth factors and various stress conditions such as hypoxia and mechanical stress. By integrating all of these different environmental conditions, TOR ensures that cells grow only when the conditions are right (5, 15).

By integrating all of these different environmental conditions, TOR ensures that cells grow only when the conditions are right.

Researchers now know that, in both invertebrate and mammalian systems, TOR combines with other proteins to form at least two structurally distinct multiprotein complexes (12). The mTOR complex 1 (mTORC1) comprises six companion proteins in addition to mTOR. The mTOR complex 2 (mTORC2) has seven accessory proteins in addition to mTOR (12). The structural differences between these two complexes affect their function, activation, and sensitivity to rapamycin.

mTORC1, which has been more widely studied, is a master controller, integrating numerous upstream and downstream signals in the cell (12). It is acutely sensitive to environmental stimuli (amino acids, glucose, growth factors, insulin, cytokines, and oxygen). Downstream, mTORC1 promotes protein, lipid, and nucleotide synthesis (regulating cell growth), promotes mitochondria biogenesis (driving cell metabolism), and inhibits the breakdown and recycling of macromolecules (10, 12, 14).

Rapamycin potently inhibits mTORC1. Under rapamycin exposure, cell growth ceases, and this

pause in growth-related tasks allows cells to focus on repairing and recycling damaged components and cleaning out cellular “junk.”

On the other hand, mTORC2 is required for maximal activation of numerous kinases and is not responsive to nutrient stimulation (10, 12). Rather, it responds to growth factors, influences cell survival, growth, and proliferation, and regulates the actin cytoskeleton and cell migration (12). Only chronic, high doses of rapamycin will inhibit mTORC2.

Life Saver

The most intriguing observation of Hall's research was that inactivating TOR—either through genetic mutations or inhibition with rapamycin—increased the lifespan of yeast cells. This effect was also seen in nematode worms and fruit flies (5, 16). Because TOR is conserved across species, scientists were keen to know whether rapamycin would produce the same life-extending effect in mammals.

At the National Institute on Aging (NIA), the Interventions Testing Program was set up to evaluate a variety of agents for their potential to extend lifespan and delay disease (15, 17). The mice in these studies were genetically heterogeneous to avoid gene-specific effects on disease susceptibility. Of the 26 compounds tested in the NIA program, only 6 (including rapamycin, metformin, acarbose, and 17 α -estradiol) gave positive results (17, 18).

Rapamycin was the only compound that showed a substantial anti-aging effect in both male and female mice. It increased lifespan by 12-25%, and the effect was dose-dependent (19, 20). Interestingly, the beneficial effect was seen not only in young adult mice (9 months)—equivalent to a 35-year-old person—but also in older mice (20 months), which equates to about 60 human years (19, 21). This suggested that an effective anti-aging intervention could be initiated later in life and still be effective in slowing, if not reversing, the aging process.

Rapamycin also seemed to improve the mice's overall health status. It retarded age-dependent declines in spontaneous in-cage activity (21). Histopathology of the mouse tissues showed evidence that rapamycin diminished age-associated changes in liver, myocardium, endometrium, adrenal, and tendons, as well as suggestive beneficial effects on ovary, thyroid, and lung (21).

End-of-life necropsies on the mice showed that the spectrum of specific lethal illnesses (mostly from cancer) was not altered by rapamycin, even though the treated animals lived longer. This suggested that rapamycin postponed tumor induction, progression, or lethality—consistent with the drug’s known anti-cancer effects (21).

These results, published in 2009, triggered massive interest. More than a dozen investigators subsequently reproduced and extended the NIA findings (10, 11, 16).

Understanding Aging

Aging is a complex process involving thousands of genes. And it is becoming more complex, as scientists uncover new layers of biology, such as epigenetics, micro-RNA, and the microbiome, all of which influence aging (22).

In the 1960s, Leonard Hayflick discovered that some human cells divide 40-60 times before stopping at what is now called the Hayflick Limit (23). Researchers have since discovered that all cells age, even if they keep dividing, and they become increasingly inefficient at basic functions such as repairing DNA and recycling proteins, lipids, and other key molecules.

Unable to maintain themselves, aging cells slowly accumulate damage, which impedes their ability to function normally and facilitate tissue repair. Senses diminish, skin goes slack, joints creak, and muscles atrophy (23). Eventually, the diseases associated with old age, disability, and death creep in: stroke, Alzheimer’s and cognitive decline, pulmonary fibrosis, kidney disease, arthritis, osteoporosis, immune decline, diabetes, heart disease, and cancer (7, 23).

Although human lifespan has doubled over the past few centuries, many elderly individuals suffer for years or decades from diseases or disorders that reduce their quality of life (22). According to one geriatric researcher, Matt Kaeberlein, “There is something about the aging process and getting older that increases the risk of getting these diseases/disorders” (7). Experts have estimated that by slowing aging, human life

expectancy would increase by 15-25 years—and those extra years would be spent in relatively good health (7).

Experts have estimated that by slowing aging, human life expectancy would increase by 15-25 years—and those extra years would be spent in relatively good health.

Encouraged by the early results with rapamycin, researchers now think that pharmacologic interventions can help the aging population live healthier for longer (18, 22).

Mighty Mice

Using mice of varying ages and genetic backgrounds, researchers have shown that rapamycin has many

beneficial effects on health.

Rapamycin has a stimulatory effect on locomotor behavior and improves memory and learning in mice (11). The drug also slows the development of kidney disease and obesity, as well as some cancers (24, 25).

In mouse models of diseases, rapamycin ameliorates the progression of atherosclerosis, Alzheimer’s disease, and muscular dystrophy (10, 21, 25, 26). In one study, the hearts of mice functioned better for longer (24). Rapamycin actually reversed the age-dependent defects in cardiac function and rejuvenated tissues in the aging heart (10, 11).

On the other hand, rapamycin has limited effects on motor coordination and balance, muscle strength, and age-related pain perception (11). There are also some age-dependent changes in male mice that are not prevented by rapamycin (20).

Overall, though, the conclusion from these studies is clear. Rapamycin slows down the aging process, not only increasing lifespan but also generally improving health span—at least in mice (7).



Matt Kaeberlein

Reprinted with permission from Matt Kaeberlein

Rapamycin slows down the aging process, not only increasing lifespan but also generally improving health span—at least in mice.

Dog Years

Studies in other mammalian species would boost support for rapamycin as a clinically relevant anti-aging agent. Dogs are a good candidate for bridging the gap between mice and people because they age about 7 times faster than humans. For studies on aging, dogs can provide results in 3-5 years (7).

Dogs have always been an attractive experimental species for evaluating human-destined drugs because they have a similar genome and develop many of the same diseases that humans do (25). In conventional laboratory experiments, inbred dogs of uniform size (usually beagles) are kept in a controlled environment.

But Matt Kaeberlein's laboratory in Seattle

has taken a different approach, recruiting companion (pet) dogs. This approach, which has been used mostly for studies of investigational cancer drugs, employs the same procedures that are used to recruit, enroll, and treat people in a clinical trial. Pet dogs are especially attractive for studies on aging (and cancer) because they are subject to similar risk factors, share the human environment, and receive comparable medical care to humans (25). Also, their detailed medical records are often available.

In 2017, Kaeberlein published the results from a Phase 1 study to determine the effects of rapamycin in companion dogs (25). Rather than following the dogs until death, Kaeberlein monitored several cardiac biomarkers associated with aging. The blinded study included 24 “middle-aged” pet dogs, which were randomized to one of two rapamycin doses or placebo (25).



Matt Kaeberlein with dogs Chloe and Dobby.

The dogs treated with rapamycin for 10 weeks showed improvement in age-related measures of heart function, indicating that their hearts were pumping blood more efficiently (24, 25). The greatest improvement was in dogs that had lower baseline cardiac function (25). These results were comparable to the cardiac improvement previously reported in middle-aged mice.

Rapamycin produced no clinical side effects and only minor changes in the dogs' blood chemistry (25). Interestingly, although the dog owners did not know the treatment assignment, in 70% of dogs receiving the rapamycin higher dose and 40% of those in the lower dose group, owners reported that their dog displayed increased activity and energy (25). Also, for 20% of dogs in the higher dose and 40% in the lower dose group, owners reported that their dogs' behavior was more affectionate. None of the placebo-treated dogs exhibited these changes. Kaeberlein speculated that this might be related to the anti-inflammatory effect of rapamycin, reducing pain associated with arthritis (25).

Although not definitive proof of an anti-aging effect, these observations were encouraging and led to follow-up studies. Kaeberlein is currently conducting a Phase 2 trial, using more dogs, treated for 6 months, and assessing additional endpoints including motor activity. This will be followed by a 5-year study in 600 pet dogs (7).

What about People?

The results in animals offer a compelling rationale for conducting clinical trials to examine the anti-aging effects of rapamycin. Considering that human life expectancy is now around 80 years, clinical trials to demonstrate a convincing anti-aging effect would take decades and would be prohibitively expensive (22, 27). In addition, receiving regulatory approval may be challenging because the FDA does not formally consider aging a disease (22, 27).

The FDA has allowed clinical trials in older adults who already have a diagnosis of at least one age-related disease (24, 28). But drug intervention to retard or reverse aging may not work in people who are already showing symptoms. For example, patients with clinically diagnosed Alzheimer's disease have already developed significant brain pathology, which is probably irreversible (7).

Finally, there are ethical concerns about long-term drug exposure in healthy older individuals (27). They are, in general, at greater risk of adverse drug reactions than young adults, due both to age-related physiological changes (e.g., lower liver and kidney function) and increased use of other medications (29).

The first evidence that drug intervention might have a beneficial effect on human lifespan came from a retrospective metaanalysis of metformin exposure. British researchers reviewed the medical records of 90,000 diabetic patients, some taking metformin and others taking a sulfonylurea as first-line therapy. These patients were matched to 90,000 control subjects who did not have diabetes (30).

The observed survival time was 38% longer in metformin-treated patients compared to patients taking a sulfonylurea. This was consistent with clinical experience, which suggests that sulfonylurea drugs have a detrimental effect on cardiovascular function (30). More surprising—and intriguing—the British analysis revealed that diabetic patients taking metformin had a 15% longer survival time than the matched control subjects, who were not diabetic and not taking metformin (30).

Metformin's primary mechanism of action is thought to be the alteration of cellular energy metabolism by stimulating 5-AMP-activated protein kinase (31). Interestingly, metformin also inhibits mTORC1 (7, 21, 31).

Unlike rapamycin and the rapalogs, metformin inhibits mTORC1 indirectly by interfering with two major input pathways. The downstream effect of inhibiting those pathways is to decrease insulin resistance and hepatic gluconeogenesis, which probably contributes to metformin's efficacy in diabetes (31). In addition, this decreased mTORC1 activity may explain metformin's apparent beneficial effect on aging (31).

Many other researchers have provided supportive evidence that metformin might protect against basic aging processes, not just diabetes (18, 22). This leads to the converse theory that drugs used to treat early-stage chronic disease may be effective, at least in part, because they target the biggest risk factor for these diseases: aging itself (18, 22).

Other supportive data come from patients who have been treated with rapamycin or a rapalog. One study assessed cognitive function and other psychiatric endpoints in heart transplant patients (32). After being

treated with immunosuppressant doses of the rapalog everolimus, patients exhibited significant improvement on several standard tests of memory, cognition, depression, and psychiatric health (32).

In another study, several biomarkers associated with cellular aging were measured in 13 elderly patients with coronary artery disease (33). Aged cells (i.e., those beyond the Hayflick Limit) express a complex biochemical profile driven by mTOR that, in turn, alters the tissue microenvironment, produces persistent inflammation, and contributes to degenerative diseases (33). In animals, rapamycin (by inhibiting mTOR) produces a favorable, dose-dependent shift in these biochemical markers (28). The clinical investigators showed that rapamycin favorably shifted the levels of several cell-aging biochemical markers, and those changes correlated with improvement in the heart patients' physical performance (33).

Only a few clinical trials have been conducted to assess the anti-aging properties of rapamycin in healthy elderly subjects, but the results so far have been encouraging.

In a randomized, controlled trial of 25 healthy adults (70-95 years), rapamycin at nonimmunosuppressant doses produced no significant differences in cognitive function between the control and treated groups (29). But interestingly, the person who scored most poorly on the pretreatment tests demonstrated improvement on cognitive measures after rapamycin treatment in this blinded trial. He also increased his walking speed by nearly 10 seconds on the 40-foot walk test. Anecdotally, his family reported improvement in his cognitive and memory abilities while he was in the study; after ending rapamycin treatment, his short-term memory grew much worse (29).

The Downside

Because rapamycin and several rapalogs have received regulatory approval, they are widely available, and physicians can legitimately prescribe them for any indication, including as an antiaging therapy. Given the large and growing body of preclinical data, few researchers doubt rapamycin's antiaging efficacy. But they are reluctant to give rapamycin or a rapalog to healthy individuals because of diverse and severe side effects (10, 34).

Most of the reported adverse effects come from treatment of patients who received high,

immunosuppressant doses. Mouth ulcers (canker sores) are a telltale sign of rapamycin in transplant medicine and an indicator that it is suppressing the patient's immune system (34, 35).

In transplant and cancer patients, rapamycin and the rapalogs can cause high blood lipids, high cholesterol (HDL and LDL), high triglycerides, glucose intolerance, insulin resistance and new-onset diabetes, anemia, thrombocytopenia, skin rashes, gastrointestinal disorders, sinusitis, respiratory and urinary infections, and testicular dysfunction (10, 12, 24, 25, 29, 35).

Many of these effects are transient and reversible (especially the skin and testicular effects), but the immunological consequences are extremely serious and occasionally result in death from infections (10).

Intermittent Dosing

The beneficial effects of rapamycin as an antiaging agent have been attributed to its inhibition of mTORC1, which in turn dampens a number of factors that mediate cell growth and aging (10-12). Researchers have attributed many of the negative side effects to inhibition of mTORC2. Fortunately, mTORC2 is inhibited only by chronic, high doses of rapamycin (10).

In one clinical study of healthy elderly subjects, rapamycin at low, nonimmunosuppressant doses produced no adverse changes in most clinical lab endpoints. No changes were seen in glucose metabolism or insulin, which differed from the increased risk of type 2 diabetes reported in transplant patients (29). Similarly, they exhibited no increases in plasma lipids, which have been reported in younger patient populations, and immune parameters were largely unchanged (29). There were several statistically significant decreases in red blood cell parameters (e.g., hemoglobin, hematocrit)—well known effects of mTOR inhibitors—but the changes were not judged to be clinically significant (29).

Rapamycin has a relatively short half-life in humans, but the terminal half-life has been reported to be 80 hours (10). This suggests that a single dose can remain in the circulation at a beneficial level for a minimum of a week (10).

Modulation of mTOR using inhibitors like rapamycin is unquestionably complicated. But the pharmacokinetics, relative inhibitory potency of rapamycin, and slow emergence of aging cells

suggest that a dosing regimen consisting of single low doses of rapamycin, given at sufficiently lengthy intervals, would selectively inhibit mTORC1 and arrest aging (10, 12). Initial research results seem to support this notion (12, 34).

A 2 mg/kg dose once every 5 days has been used most frequently in animal studies. This regimen produces no impairment of glucose homeostasis and reduces the impact on the immune system, while still significantly inhibiting mTORC1 in many tissues (10). This regimen of rapamycin significantly increased lifespan in female mice, suggesting there is a therapeutic window in which the antiaging effects (mediated by mTORC1 inhibition) can be achieved while minimizing mTORC2-related side effects (10).

Investigators at Novartis evaluated the effects of the company's rapamycin analog, everolimus, in 211 healthy elderly subjects (35). Subjects were randomly assigned to a placebo, a low dose of everolimus administered daily, or one of two nonimmunosuppressant doses administered weekly.

Rather than monitoring time to death (which was not feasible), the investigators used a biomarker as an indicator of aging status: immune responsiveness to vaccination. Adults over 65 have a lower antibody response to influenza vaccination compared to younger adults, due to an accumulation of age-related immune defects (35).

Subjects in the Novartis study were treated for 6 weeks. Two weeks after the end of treatment, they received an influenza vaccination. Everolimus enhanced the antibody response to influenza vaccination by about 20% compared to the placebo group (35). This was consistent with previous studies that showed the same beneficial effect in aged mice.

The Novartis researchers confirmed the vaccine-responsiveness effect in a follow up placebo-controlled study of 264 elderly subjects (36). Two mTORC1 inhibitors (everolimus or dactolisib) were given for 6 weeks. Interestingly, the subjects in the drug-treated groups also exhibited a significantly lower rate of infections for 1 year following treatment, compared to the placebo group (36).

It may seem paradoxical for a drug, which (like rapamycin) is known and used clinically as an immunosuppressant, to enhance immune responsiveness (35). But the immunomodulatory

effects of the rapalogs appear to depend on several factors, including dose.

The goal in transplant patients is to completely suppress mTOR activity (and immune function) with high-dose rapamycin. In aged tissues, the activity of mTOR progressively increases, impeding normal function and repair compared to younger tissues and organs (5, 35). The beneficial effects on immune response to vaccination and infection rate in the elderly subjects was achieved with low, short, and intermittent dosing regimens, which apparently shifted mTOR activity down to the "healthy" levels that are typical of young tissues (35). That is, the treatment regimens used in the Novartis studies helped the elderly subjects' immune system to work better (5).

The Pudding's Proof

The extensive preclinical data and limited clinical findings provide convincing evidence to justify further research. Based on that evidence, Kaeberlein predicts that an appropriate mTOR inhibitor could add a couple of decades to human lifespan, "with the expectation that those years are going to be spent in relatively good health" (24).

But there is a lack of clarity regarding the optimal dose and treatment schedule needed to maximize the benefit/risk ratio (10, 16). Some researchers are optimizing rapamycin's anti-aging properties by creating more selective rapalogs. Other researchers are devising selective mTORC1 inhibitors that have novel chemical structures (7). Torin 1 and dactolisib, which block the mTOR catalytic subunit, represent yet another approach.

A few passionate physicians are already convinced that rapamycin is the Fountain of Youth. Dismissing the need for definitive proof, they have begun prescribing low-dose intermittent rapamycin off-label for their patients or themselves.

But most mTOR researchers, given the option, say they wouldn't take it. They see rapamycin's potential, but they are waiting for an appropriately selective compound and dosing conditions that demonstrate a bona fide clinical response (5). Until then, Judith Campisi, a professor at Buck Institute for Research on Aging, says, "When people ask me how to stay young, I say: exercise, don't smoke, eat your veggies, and choose your grandparents wisely" (22).

References

1. Beighton P (1966) Easter Island people. *Geogr J* **132(3)**: 347-357.
2. Boutilier JA (1992) METEI: A Canadian medical expedition to Easter Island, 1964-1965. *Rapa Nui J* **6(2)**: 21-23, 26-33.
3. Duffin J (2016) Peter Beighton on Rapa Nui (Easter Island), 1964-1965. *South African Med J* **106(6)** (Suppl 1): S21-S22.
4. Tang L (2018) *Summary & Study Guide – The Fountain: A Doctor's Prescription to Make 60 the New 30*. CreateSpace Independent Publishing Platform.
5. Halford B (July 18, 2016) Rapamycin's secrets unearthed. *Chem Eng News* **94(29)**: 26-30.
6. Boutilier JA (1992) MEITI: A Canadian medical expedition to Easter Island, 1964-1965. *Rapa Nui J* **6(3)**: 45-53.
7. Kaeberlein M (September 22, 2016) Chemistry of longevity: rapamycin's secret past and potential for a longer life. Amer Chem Soc webinar; available from https://www.acs.org/content/acs/en/acs-webinars/popular-chemistry/longevity.html?_ga=2.113645250.491211744.1543960192-1214168268.1543960192
8. Sehgal A (2003) Suren's Story; available from: <http://www.sehgal.net/surensstory.htm>.
9. Garber K (2001) Rapamycin's resurrection: a new way to target the cancer cell cycle. *J Nat Cancer Inst* **93(20)**: 1517-1519.
10. Apelo SIA and Lamming DW (2016) Rapamycin: an inhibiTOR of aging emerges from the soil of Easter Island. *J Gerontol A Biol Sci Med Sci* **71(7)**: 841-849.
11. Ehninger D, Neff F, and Xie K (2014) Longevity, aging and rapamycin. *Cell Mol Life Sci* **71**: 4325-4346.
12. Ong PS, Wang LZ, Dai X, Tseng SH, Loo SJ, and Sethi G (2016) Judicious toggling of mTOR activity to combat insulin resistance and cancer: current evidence and perspectives. *Front Pharmacol* **7**:395: <https://www.frontiersin.org/articles/10.3389/fphar.2016.00395/full>
13. Hall MN (2016) TOR and paradigm change: cell growth is controlled. *Mol Biol Cell* **27(18)**: 2804-2806.
14. Strauss E (2017) Nutrient-activated TOR proteins that regulate cell growth, 2017 Lasker awards; available from: <http://www.laskerfoundation.org/awards/show/nutrient-activated-tor-proteins-regulate-cell-growth>.
15. Hasty P (2010) Rapamycin: the cure for all that ails. *J Mol Cell Biol* **2(1)**: 17-19.
16. Kaeberlein M (2014) Rapamycin and aging: when, for how long, and how much? *J Genet Genomics* **41(9)**: 459-463.
17. Nadon NL, Strong R, Miller RA, and Harrison DE (2017) NIA interventions testing program: Investigating putative aging intervention agents in a genetically heterogeneous mouse model. *EBioMedicine* **21**: 3-4.
18. Barzilai N, Cuervo AM, and Austad S (September 17, 2018) Aging as a biological target for prevention and therapy. *JAMA* **320(13)**:1321–1322; doi:10.1001/jama.2018.9562.
19. Harrison DE, Strong R, Sharp ZD, Nelson JF, Astle CM, Flurkey K, Nadon NL, Wilkinson JE, Frenkel K, Carter CS, et al. (2009) Rapamycin fed late in life extends lifespan in genetically heterogeneous mice. *Nature* **460(7253)**: 392-395.
20. Miller RA, Harrison DE, Astle CM, Fernandez E, Flurkey K, Han M, Javors MA, Li X, Nadon NL, Nelson JF, et al. (2014) Rapamycin-mediated lifespan increase in mice is dose and sex dependent and metabolically distinct from dietary restriction. *Aging Cell* **13(3)**: 468-477.
21. Miller RA, Harrison DE, Astle CM, Baur JA, Boyd AR, de Cabo R, Fernandez E, Flurkey K, Javors MA, Nelson JF, et al. (2011) Rapamycin, but not resveratrol or simvastatin, extends life span of genetically heterogeneous mice. *J Gerontol A Biol Sci Med Sci* **66A(2)**: 191-201.
22. Everts S (March 6, 2017) Can we hit the snooze button on aging? *Chem Eng News* **95(10)**:31-35.
23. Zaleski A (Summer 2018) Forever Man, *Popular Sci*, pp 108-113.
24. Harmon A (May 16, 2016) Dogs test drug aimed at humans' biggest killer: age. *New York Times*; available from: <https://www.nytimes.com/2016/05/17/us/aging-research-disease-dogs.html>.
25. Ufer SR, Kaeberlein TL, Mailheau S, Bergman PJ, Creevy KE, Promislow DEL, and Kaeberlein M (2017) A randomized controlled trial to establish effects of short-term rapamycin treatment in 24 middle-aged companion dogs. *GeroScience* **39(2)**: 117-127.
26. Hartman B (February 8, 2018) Researchers report promising anti-aging rapamycin clinical trial results. Longevityfacts.com; available from: <http://longevityfacts.com/researchers-report-rapamycin-clinical-trial-results>.
27. Kennedy BK and Pennypacker JK (2015) Aging interventions get human. *Oncotarget* **6(2)**: 590-591.
28. Tchkonja T and Kirkland J L (September 17, 2018) Aging, cell senescence, and chronic disease: emerging therapeutic strategies. *JAMA* **320(13)**: 1319-1320; doi: 10.1001/jama.2018.12440.
29. Kraig E, Linehan LA, Liang H, Romo TQ, Liu Q, Wu Y, Benavides AD, Curiel TJ, Javors MA, Musi N, et al. (2018) A randomized control trial to establish the feasibility and safety of rapamycin treatment in an older human cohort: immunological, physical performance, and cognitive effects. *Exp Gerontol* **105**: 53-69; doi: 10.1016/j.exger.2017.12.026.
30. Bannister CA, Holden SE, Jenkins-Jones S, Morgan CL, Halcox JP, Scherthaner G, Mukherjee J, and Currie CJ (2014) Can people with type 2 diabetes live longer than those without? A comparison of mortality in people initiated with metformin or sulphonylurea monotherapy and matched, non-diabetic controls. *Diabetes Obe Metab* **16(11)**: 1165-1173; doi: 10.1111/dom.12354.

31. Melnik BC and Schmitz G (2014) Metformin: an inhibitor of mTORC1 signaling. *J Endocrinology, Diabetes Obes* **2(2)**: 1029.
32. Lang UE, Heger J, Willbring M, Domula M, Matschke K, and Tugtekin SM (2009) Immunosuppression using the mammalian target of rapamycin (mTOR) inhibitor everolimus: Pilot study shows significant cognitive and affective improvement. *Transplant Proc* **41(10)**: 4285-4288.
33. Singh M, Jensen MD, Lerman A, et al (2016) Effect of low-dose rapamycin on senescence markers and physical functioning in older adults with coronary artery disease: results of a pilot study. *J Frailty Aging* **5(4)**: 204-207.
34. Hartman B (August 17, 2017) Can we slow aging in our bodies with intermittent rapamycin therapy? LongevityFacts.com,; available from: <http://longevityfacts.com/stop-aging-intermittent-rapamycin>.
35. Mannick JB, Del Giudice G, Lattanzi M, Valiante NM, Praestgaard J, Huang B, Lonetto MA, Maecker HT, Kovarik J, Carson S, et al. (2014) mTOR inhibition improves immune function in the elderly. *Sci Transl Med* **6(268)**: 268rs179; doi: 10.1126/scitranslmed.300892.
36. Mannick JB, Morris M, Hockey HP, Roma G, Beibel M, Kulmatycki K, Watkins M, Shavlakadze T, Zhou W, Quinn D, et al. (2018) TORC1 inhibition enhances immune function and reduces infections in the elderly. *Sci Transl Med* **10(449)**: eaaq1564; doi: 10.1126/scitranslmed.aaq1564.



The Pharmacologist,
Volume 60,
Number 4,
December 2018

Sixty Years of Benzodiazepines

Rebecca J. Anderson, PhD

Everybody knows what anxiety is. But crafting a concise clinical definition is difficult because anxiety is an emotion with complex attributes. It results from situations of real or perceived danger, threat, or other unpleasant experience. Increasingly, in our modern society, it may be triggered merely by feelings of insufficiency in coping with the stresses of family, professional life, or society (1). It may be present continuously or intermittently (2). And the symptoms can be expressed predominantly as psychological or physical—or maybe both (1).

Since ancient times, people have attempted to alleviate their anxiety using chemicals. Many found relief with natural products like alcohol, marijuana, and opium (1). In the early 20th century, practitioners realized that an important component of anxiety was a heightened arousal, expressed as nervousness, restlessness, agitation, or tension (1, 3). To reduce the level of arousal and alertness, they prescribed “sedatives,” primarily barbiturates. But the risks associated with barbiturates far outweighed their advantages. They impaired intellectual and motor skills, had considerable abuse potential, and overdosing deaths were far too common (3).

The modern era of drug treatment for anxiety began in 1955 with the introduction of meprobamate (1). Frank Berger at Carter Wallace Laboratories was looking for a longer-acting central muscle relaxant (4). But clinicians discovered that Berger’s compound, meprobamate, also curbed anxiety—and without undue sedation (3).

By the late 1950s, meprobamate was the most popular psychotropic agent in the U.S. (1). It was widely prescribed by psychiatrists as an outpatient treatment, as well as by general practitioners (3).

Reprinted with permission from Tommy Grove, PharmD

Unfortunately, overuse soon made meprobamate's addiction potential apparent. In general practice, clinicians found that meprobamate was not much less sedative or addictive than the barbiturates and almost as dangerous in overdose (1,3).

In parallel with meprobamate, chlorpromazine was approved by the Food and Drug Administration (FDA). Although chlorpromazine was not recognized at that time as a specific treatment for schizophrenia, it clearly had a direct effect on mood disorders. Equally significant, it established that a chemical could provide relief from psychiatric illness—a sharp departure from the prevailing practice of Freudian psychoanalysis among psychiatrists. The term “tranquilizer” was coined for meprobamate and chlorpromazine to describe their vague, psychotropic effects (1).

Meprobamate and chlorpromazine's introduction marked the beginning of psychopharmacology and prompted pharmaceutical companies to search for other drugs to treat psychiatric illnesses (2). At Hoffmann-La Roche, senior managers charged their chemists with finding a “psychosedative” drug that could be patented and would represent a qualitative improvement on the existing tranquilizers (1, 3). Among those Roche chemists was a brash but accomplished senior research chemist named Leo Sternbach.



Leo Sternbach

The Consummate Chemist

Leo Henryk Sternbach was born in what is now Croatia in 1908. His father was Polish and his mother was Hungarian. Because neither spoke the other's

language, German was their common language at home (3). As a child, Leo helped in his father's pharmacy shop and learned Hungarian from his mother at home.

Because of post-World War I economic pressure and the shifting of international borders in eastern Europe, Leo's family moved several times. Leo attended German language secondary schools in Austria and Silesia (southern Poland). The family finally settled in Krakow, Poland, and became citizens there. Leo's father opened a pharmacy in the Jewish ghetto. Leo graduated from high school in 1926, while cramming to learn Polish (3).

Although not a practicing Jew, Leo faced anti-Semitism throughout his early schooling. Jewish students were effectively barred from studying pharmacy or medicine. But he was accepted in the pharmacy program at the University of Krakow because his father had become an established pharmacist before it was denied to Jews (3). His father hoped that Leo would eventually take over the family business, but Leo's interest lay in chemistry. He saw the study of pharmacy as his path to that goal.

In pharmacy school, Leo acquired extensive knowledge of botany and learned how to make extracts, infusions, and tinctures from leaves, roots, and bark. He received his master's degree in pharmacy in 1929 and his PhD in organic chemistry in 1931. He stayed at the university as a chemistry research assistant and lecturer until 1936, when the university took steps to fill his post with a Polish Christian (3).

Sternbach received a scholarship financed by Feliks Wislicki, a Jewish textile magnate, and moved to Vienna. At the University of Vienna, he briefly worked in colloid, organic, and medicinal chemistry. Then, he landed a position at the Federal Institute of Technology in Zurich, Switzerland. When the Wislicki scholarship expired in March 1939, Sternbach continued employment at the Institute with support from the Rockefeller Foundation (3).

Life became uncertain for the Sternbach family after Germany invaded Poland on September 1, 1939. In Switzerland, Leo was spared the anti-Semitism he had encountered in Austria and Poland. In the prevailing political environment, he could not return to his family in Krakow (1, 3).

Sternbach learned that the Basel-based pharmaceutical company Hoffmann-La Roche was looking for a research chemist. Like other Swiss companies, Roche employed Jews and protected their careers. Sternbach interviewed with the Roche chairman, Emil Christoph Barell, and was offered a position in 1940 (3). His first assignment at Roche was to work on the synthesis of riboflavin (vitamin B₂).



In the public domain.

Emil Barell (left) and Fritz Hoffmann-La Roche (right) in 1898

When Hitler invaded Yugoslavia, Greece, the Soviet Union, and North Africa in 1941, neutral Switzerland found itself in a precarious position, surrounded by Axis powers. In May, Barell made the decision to move the company's headquarters from Basel to Nutley, New Jersey (3).

The Nutley site had been manufacturing Roche products as a subsidiary before the war. In particular, Roche was one of the principal suppliers of vitamins to the US and its allies. Barell set up operations to

ensure that for the duration of the war, Roche could ship its products from the US if they could no longer be supplied from Basel.

In addition to the new corporate headquarters, Barell established a research facility in Nutley and relocated many of Roche's best researchers to staff it, including Leo Sternbach. Having mastered German, Hungarian, and Polish, Sternbach now learned a fourth language, American English (3).

Sternbach's first assignment in Nutley was to compare various samples of commercial beta-ionone to establish which was the best starting material for synthesis of vitamin A. His next project was synthesis of water-soluble arsenicals, which were aimed at treating syphilis and could compete with a recently introduced product, Mapharsan. The third project was synthesis of warfarin-like compounds to be used as anticoagulants (3). Sternbach did not consider these projects very challenging, and they were soon discontinued.

A contributing factor was Sternbach's sharp criticism of his superiors, especially those trained as chemists. In his first few months in Nutley, he repeatedly clashed with his bosses and rapidly transferred from one to the next. According to Sternbach, "those who were above me were not my favorites" (3).

Sternbach never doubted his chemical expertise and demanded his bosses' support to work independently. He wanted to follow "the right path," as he saw it, without their interference. Once he made up his mind, he could not be dissuaded. With boundless energy, he overcame all resistance and obstacles, regardless of whether they involved chemistry, personnel, or the company hierarchy (3).

Sternbach was also extremely demanding toward his subordinates and expected their loyal assistance. But for them, he concealed his drive for independence behind warm amiability, and his proud self-confidence behind a charming modesty (3). He was highly respected, and whenever possible, he avoided quarrels. But when angered, he could explode with a string of expletives, often forcefully expressed in Polish. Then, just as quickly, he would cool down and reestablish his basic kindness.

Biotin Breakthrough

Following his uninspiring early assignments, Sternbach's next contribution caught everyone's attention at Roche. In 1940, Vincent du Vigneaud

discovered that biotin (which had first been identified as a yeast growth factor) was also a mammalian vitamin (vitamin B₇). Du Vigneaud had isolated biotin from liver extracts and milk in his laboratory at Cornell University (5). Subsequently, chemists at Merck and Lederle successfully synthesized biotin. But their methods produced extremely low yields, and the vitamin was not commercially viable.

In February 1943, Sternbach started work to synthesize biotin at Roche. His improved method produced a 10-fold greater yield. Roche patented Sternbach's method and began including biotin in its multivitamin preparations. This forced other manufacturers to also include biotin in their multivitamins, and they had to buy biotin from Roche—a real windfall for the company (3).

The success of biotin propelled Sternbach into the select group of Roche's top researchers (3). And biotin was just the first in a string of commercially successful products that Sternbach synthesized: spasmolytics, selective muscarinic receptor blockers, and antihypertensives (1).

Where to Start?

When Roche mandated a research effort to find a new “psychosedative” drug, Sternbach took up the challenge, along with a number of his colleagues. Because Roche wanted a chemically novel drug, the chemists could not simply modify the known active compounds using structure-activity relationships (1, 3). Besides, they knew several competing research groups were already optimizing and patenting active analogs of meprobamate and chlorpromazine (6).

Modifying brain chemistry in a targeted manner was also impossible because, at that time, almost nothing was known about brain processes or biochemistry (3, 6). In fact, despite chlorpromazine's proven efficacy, many psychiatrists still doubted any connection between brain chemistry and psychiatric illness.

Fortunately, behavioral pharmacology worked in the chemists' favor. Animal tests had been developed and proven to be reliable for detecting the pharmacologic actions of sedatives and tranquilizers (3, 6). But the chemists still needed a starting point, and there were only two possible strategies left.

They could pull old compounds off the shelf and screen them in the animals for “psychosedative” activity. Many drug companies in later decades would

Modifying brain chemistry in a targeted manner was also impossible because, at that time, almost nothing was known about brain processes or biochemistry.

rely on such “high throughput screening” strategies to identify chemical leads. But for reasons that are unclear, this approach was not considered or followed by the Roche chemists (1).

Alternatively, they could create a priori novel structures unrelated to known drugs. Undoubtedly, the Roche chemists proposed many molecular options. The details of these novel chemical structures are unknown, but we can conclude, based on the lack of patents and publications, that those compounds did not produce desirable pharmacologic results (1). Leo Sternbach was the exception.

The Dye that Didn't Die

In his first 10 years with Roche, Sternbach had acquired considerable medicinal chemistry experience (1). He drew on that practical insight and tackled this new problem in a purely empirical manner (6). In the absence of a logical starting point, Sternbach made choices based on compounds that were relatively unresearched, were easily accessible, and offered the potential for making a variety of analogs (3, 6).

Twenty years earlier, as a postdoctoral assistant at the University of Krakow, Sternbach had researched new azo dyes and dyestuff intermediates (1, 3, 6). His efforts, preparing a group of benzoheptoxodiazines, had involved interesting chemistry, and he produced good yields. But none of the chemicals were useful as dyes (6). Sternbach published his work in a Polish chemical journal and moved to other projects.

Now at Roche, Sternbach remembered those benzoheptoxodiazines, which “looked rather attractive to us and seemed to be well suited for a fairly broad synthetic program” (6). From his earlier work, Sternbach knew these compounds were easy to synthesize, isolate, purify, and crystallize. He did a literature search and found that very little had been published on the chemistry of the compounds, and no studies of their biological properties had been performed (1, 6).

Sternbach made a number of heptoxodiazine analogs. In the course of this work, he realized that the chemical structure of some of the analogs were quinazolines rather than heptoxodiazines (1, 2, 6). Because the quinazoline compounds represented another interesting and novel chemical structure, he proceeded to make a series of about 40 analogs, all of which were easy to synthesize and formed nice crystals (2). “Unfortunately, the pharmacologic properties were rather disappointing” (6).

Sternbach trusted his instincts. And he was not shy about showing that he was more knowledgeable in chemistry than almost anyone else. His sheer joy of chemistry drove him to pursue anything that grabbed him emotionally or fired his intuition. So he soldiered on, with a legendary tenacity.

But by the latter half of 1955, he had lost the confidence of his boss, who felt Sternbach was following a fruitless and dead-end path. He demanded that Sternbach abandon his work on the quinazolines and focus on higher priority projects (1, 3, 6).

Sternbach switched to isolating, purifying, and degrading various antibiotics (6). By April 1957, he was running out of workspace. His lab benches were covered with dishes, flasks, and beakers—all containing various samples and mother liquors. He needed to do some radical spring cleaning and clear out lab space (3, 6).

One Last Chance

During the cleanup operation, Sternbach’s coworker, Earl Reeder, discovered a few hundred milligrams of two compounds: a crystalline base and its hydrochloride salt. Sternbach and Reeder had prepared the base in 1955 and the HCl salt in 1956 (3). Because of Sternbach’s reassignment, the compounds had been tucked away and never tested (6).

In May 1957, Sternbach submitted the water-soluble salt for pharmacological evaluation under code number Ro 5-0690 (1, 6). He promised the pharmacologists that this would be the last compound from the series he would submit (1). He expected negative results, but it would wrap up their work on the quinazoline series, and at least they hoped to publish their work in a chemical journal (6).

A few days later, Lowell O. Randall, director of Roche’s pharmacology department, telephoned Sternbach. Randall had been trained as a biochemist

and had almost 20 years of experience as an industrial pharmacologist and toxicologist, first at Burroughs Wellcome and then at Hoffmann-La Roche. His main interest had been in autonomic pharmacology and in analgesic and anti-inflammatory drugs (1).

Randall directly supervised Roche’s primary screening of compounds for CNS activity (1). And he was enthusiastic about Ro 5-0690. “The compound exhibited unusually interesting qualities” (6). It was a potent muscle relaxant and sedative with no general anesthetic properties, was apparently devoid of autonomic effects, and had very low toxicity (1).

Randall compared Ro 5-0690’s activity to the then-most frequently used tranquilizers (meprobamate and chlorpromazine) and a reference anticonvulsant (phenobarbital). Ro 5-0690 was more effective than meprobamate in each of Randall’s six preliminary tests. Compared to chlorpromazine, Ro 5-0690 was weaker in the mouse inclined screen and rat foot shock tests, equally effective as a muscle relaxant in the cat, and had a more pronounced anticonvulsant effect (6, 7). The absence of a direct hypnotic effect was another interesting feature and differentiated it from phenobarbital. And unlike chlorpromazine, it had no effect at all on the autonomic nervous system (6, 7).

To Sternbach, “It looked like an ideal compound” (6). He synthesized larger quantities of Ro 5-0690, and Randall put it through a whole gamut of animal tests to define its pharmacological and psychotropic properties (1).

In parallel, Sternbach examined more closely the chemistry of Ro 5-0690. He definitively identified its chemical structure—which proved to be a benzodiazepine rather than a quinazoline—and called it methaminodiazepoxide. Later, the generic name was changed to chlordiazepoxide (1, 6). Sternbach also produced a number of analogs, but none of them proved superior to Ro 5-0690.

Roche filed a patent on the benzodiazepine series in May 1958, and Randall completed the preclinical safety testing of chlordiazepoxide (1, 6). Toward the end of 1959, he presented the pharmacological properties of chlordiazepoxide at a scientific meeting (1). What impressed the pharmacologists more than any other aspect was the drug’s “taming” effect. Although no accepted animal models of anxiety existed in the 1950s, Randall reported that chlordiazepoxide suppressed aggressive animal behavior (1). The drug had tamed a colony of vicious



Reprinted with permission from F. Hoffmann-La Roche Ltd.

The picture at left shows a growling caged lynx at the San Diego Zoo. The same lynx nuzzles a wild flower on the right after being given chlordiazepoxide.

cynomolgus monkeys at doses that did not affect their level of alertness or other behavioral responses—an “anxiolytic” type of activity. (7)

Those observations were confirmed by veterinarian Werner Heuschele, who was asked to test chlordiazepoxide at the San Diego Zoo (8). Unlike previous tranquilizers, which made the animals groggy, Heuschele found that chlordiazepoxide allowed animals to remain active but made them genuinely gentle and friendly. For example, it transformed a fierce 40-pound lynx into a tranquil tabby, which gamboled lamblike in its cage, allowed its ears to be scratched, and rolled over on its back to have its belly stroked (8). Heuschele had equal success in calming a mean Australian dingo, Tasmanian devil, Sumatran tiger, red kangaroo, and baboon (8).

Sternbach himself took the compound and told the Associated Press: “It had no unpleasant side-effects. It gave you a feeling of well-being” (1). He subsequently tested many of his compounds on himself (9).

The marked anticonvulsant and muscle relaxant activities of chlordiazepoxide were clearly more widely separated from the lethal dose than the safety margins of meprobamate and phenobarbital (7). And Randall found no relevant organ toxicity (7).

Clinical Persistence

Clinical trials began in 1958 under Leonard Hines, Roche’s director of biological research (1, 6). The first studies enrolled healthy volunteers and institutionalized elderly patients, who were given rather high doses (2). Chlordiazepoxide produced marked sleepiness, dizziness, ataxia, and slurred speech (1, 2). It looked no different than other sedative drugs, and Roche suspended the clinical trials for several months (1).

Then, Hines convinced Irvin Cohen, a psychiatrist in Galveston, Texas, and two other practitioners to try chlordiazepoxide on some of their outpatients suffering from anxiety and mild depression (1, 2). They administered lower doses and found that

chlordiazepoxide calmed tension, reduced anxiety, and improved sleep with a minimum of side effects (1).

Although the optimal dose was still uncertain, drowsiness and ataxia could be avoided by adjusting the dose. Increased appetite, interest in social activity, and verbal productivity, as well as a feeling of well-being, suggested that the drug had some kind of psychostimulant effect (1).

Interest among clinical investigators became so great that thousands of patients were soon enrolled in the trials and treated with the drug. The clinical trials (and clinical experience in millions of patients over the next 20 years) confirmed the low toxicity and large safety margin of the benzodiazepines (1, 6).

Chlordiazepoxide was approved by the FDA in February 1960—less than two and a half years after Randall's first pharmacological tests. Roche marketed the drug as Librium®—from “equilibrium” (1, 6, 8).

The rapid onset of therapeutic effect in low doses with only minor side effects (perhaps together with the suggestive tradename) impressed both physicians and patients. They enthusiastically embraced Librium as the preferred treatment for anxiety (1).



Diazepam tablets

A Bigger Hit

During the two years that chlordiazepoxide was in clinical trials, very little effort was put into further benzodiazepine research. It was only when Librium approached market introduction that work resumed (1). One drawback of chlordiazepoxide was that the water-soluble salt, which had been developed for the clinic, was extremely bitter. In addition, the compound was unstable in aqueous solution (1, 6). This made it unsuitable for liquid formulations. As a follow up, Sternbach set out to find a tasteless analog that could be used in elixir or syrup formulations for pediatric and geriatric use.

Along with developing more efficient chemical synthesis methods, Sternbach's structure-activity studies helped to elucidate features of the molecule that were essential for pharmacologic activity (6). All of the active benzodiazepine compounds had a similar pharmacologic profile, but one, the 1-methyl derivative, was significantly more potent than chlordiazepoxide.

Hoping that the greater potency would provide advantages in the clinic, Sternbach and Randall intensively studied the compound, which they named diazepam. It had a greater separation between anxiolytic and sedative effects than chlordiazepoxide (2, 3). And the toxicology studies showed that diazepam was extremely safe (6).

Roche first marketed diazepam under the tradename Valium® (from the Latin, *valere*, meaning “to be strong,” and the suffix of Librium) in 1963 (2). Valium largely replaced Librium, and by the end of the 1960s, it was the best-selling psychotropic drug in the western world (3).

As soon as the chlordiazepoxide patent appeared, researchers at other companies began investigating benzodiazepine derivatives, too. Wyeth researchers discovered the biological activity of the analog, oxazepam, which they patented in 1965.

But Sternbach and his team at Roche remained at the forefront of benzodiazepine research. The clinical success of Valium led to Sternbach's promotion to director of medicinal chemistry. He greatly enlarged Roche's chemistry staff, and the Pharmacology Department expanded proportionately (6). Over the next 25 years, they synthesized and pharmacologically evaluated more than 3,000 benzodiazepines, churning out new products like a virtual factory (1, 3, 6).

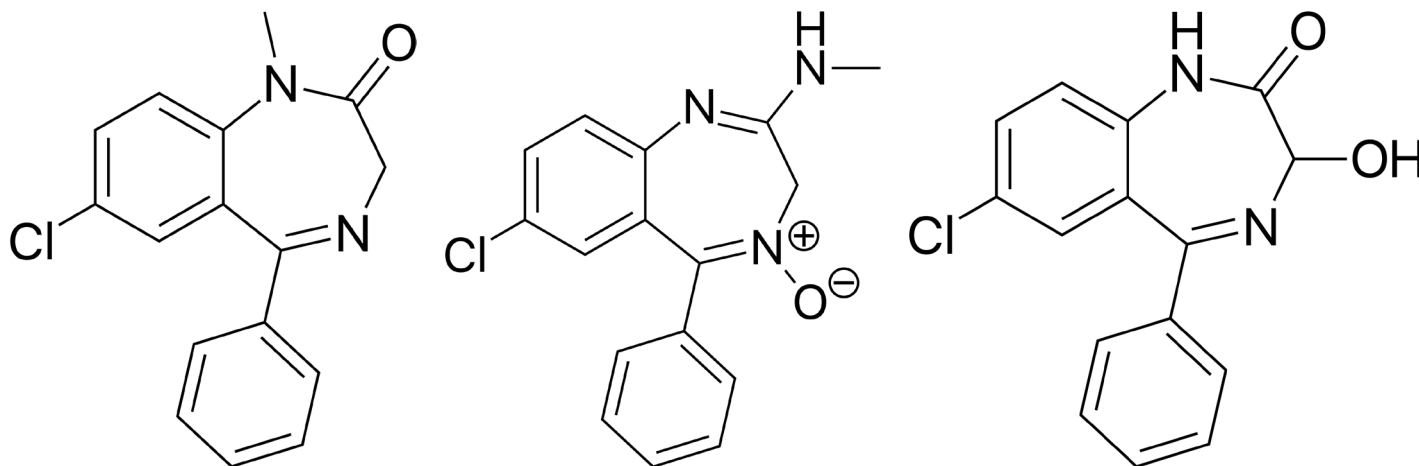

Structures of diazepam, chlordiazepoxide, and oxazepam

Channeled Chaos

Sternbach's fellow chemists admired his mastery of laboratory skills. He worked with precision and concentration, and his command of crystallization was unequalled (3). To the outsider, his lab bench was chaotic: a jumble of tubes and Erlenmeyer flasks. "Sternbach wrote up his research reports absolutely correctly, although they were thoroughly confusing to everybody else; sometimes he started at the front of the notebook, sometimes at the back" (3).

Sternbach had a knack for surrounding himself with competent people and successfully motivating them. Despite his volatile temperament, he could be a brilliant team worker, fostering collaborations at all levels. He worked closely with Randall's pharmacology team, supported them, and openly communicated with them (3).

Fairness was the rule on Sternbach's team, and to them, he exhibited nothing but enthusiasm, openness, and infinite patience. He also took an interest in their personal problems, even giving them financial support when necessary (3).

Sternbach dealt with problems efficiently, which often meant bypassing official channels. He was obstinate, fired by optimism and self-confidence, and trusted his instincts. But he was also an unwavering realist. When the results differed from his preconceived notions, he relented, saying, "Life is how it is" (3).

A Class Act

Librium and Valium triggered a worldwide industry search for more selective benzodiazepines. Thousands of patents and tens of thousands of

research papers were published on benzodiazepine chemistry, pharmacology, and clinical effects (6). By the 1980s, those efforts resulted in more than 30 marketed benzodiazepines (1).

All of them possessed pharmacologic properties that are characteristic of this drug class: muscle relaxant, sedative, antianxiety, anticonvulsant, and hypnotic. But each compound exhibits relatively greater or lesser effects: one may be more hypnotic, another more anxiolytic, and a third more anticonvulsant (3). They also differ in their physicochemical properties, pharmacokinetic behavior, and susceptibility to metabolism.

Probing the Brain

For the first 15 years after the introduction of chlordiazepoxide, clinicians knew little or nothing about how the benzodiazepines worked (3). Research focused on descriptive aspects of the drugs' actions, primarily the anticonvulsant effect (1).

In 1965, diazepam was established as an effective treatment for status epilepticus (10). Status epilepticus is a neurologic emergency characterized by a prolonged, self-sustained, and potentially life-threatening seizure. It is often refractory to treatment. By 1969, diazepam was recommended as (and remains) the drug of choice because it is effective against a variety of seizure types, has a rapid onset of action, and is relatively safe (10).

Studies on the muscle relaxant effect revealed an absence of action on the neuromuscular junction (1). In 1967, the first hint of a neuronal mechanism of action came from a report that diazepam enhanced

Her world orbits around doctors. Psychic tension rules her universe.

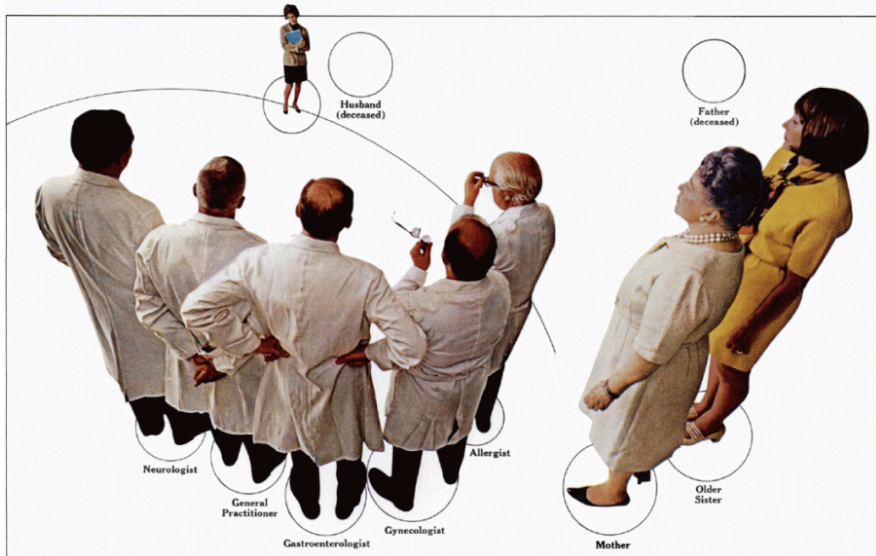

This childless widow's interpersonal relationships, sociometrically diagrammed, reveal the patterns of dominance, closeness, absence, and loss created by the principal people in her life.



By relieving undue psychic tension, it can help:

- ease patients into therapy,
- lessen emotional stress reaction to crisis situations,
- improve communication,
- reduce tension-induced insomnia,
- relieve stress-induced psychosomatic symptoms,
- support the patient between therapeutic sessions.

Before prescribing, please consult complete product information, a summary of which follows:

Indications: Tension and anxiety states; somatic complaints which are concomitants of emotional factors; psychoneurotic states manifested by tension, anxiety, apprehension, fatigue, depressive symptoms or agitation; symptomatic relief of acute agitation, tremor, delirium tremens and hallucinosis due to acute alcohol withdrawal; adjunctively in skeletal muscle spasm due to reflex spasm to local pathology, spasticity caused by upper motor neuron disorders, athetosis, stiff-man syndrome, convulsive disorders (not for sole therapy).

Contraindicated: Known hypersensitivity to the drug. Children under 6 months of age. Acute narrow angle glaucoma; may be used in patients with open angle glaucoma who are receiving appropriate therapy.

Warnings: Not of value in psychotic patients. Caution against hazardous occupations requiring complete mental alertness. When used adjunctively in convulsive disorders, possibility of increase in frequency and/or severity of grand mal seizures may require increased dosage of standard anticonvulsant medication; abrupt withdrawal may be associated with temporary increase in frequency and/or severity of seizures. Advise against

simultaneous ingestion of alcohol and other CNS depressants. Withdrawal symptoms (similar to those with barbiturates and alcohol) have occurred following abrupt discontinuance (convulsions, tremor, abdominal and muscle cramps, vomiting and sweating). Keep addiction-prone individuals under careful surveillance because of their predisposition to habituation and dependence. In pregnancy, lactation, or women of childbearing age, weigh potential benefit against possible hazard.

Precautions: If combined with other psychotropics or anticonvulsants, consider carefully pharmacology of agents employed; drugs such as phenothiazines, narcotics, barbiturates, MAO inhibitors and other antidepressants may potentiate its action. Usual precautions indicated in patients severely depressed, or with latent depression, or with suicidal tendencies. Observe usual precautions in impaired renal or hepatic function. Limit dosage to smallest effective amount in elderly and debilitated to preclude ataxia or oversedation.

Side Effects: Drowsiness, confusion, diplopia, hypotension, changes in libido, nausea, fatigue, depression, dysarthria, jaundice, skin rash, ataxia, constipation, headache, incontinence, changes in salivation, slurred speech, tremor, vertigo, urinary retention, blurred vision. Paradoxical reactions such

as acute hyperexcited states, anxiety, hallucinations, increased muscle spasticity, insomnia, rage, sleep disturbances, stimulation have been reported; should these occur, discontinue drug. Isolated reports of neutropenia, jaundice; periodic blood counts and liver function tests advisable during long-term therapy.

Dosage: Individualize for maximum beneficial effect. **Adults:** Tension, anxiety and psychoneurotic states, 2 to 10 mg b.i.d. to q.i.d.; alcoholism, 10 mg t.i.d. or q.i.d. in first 24 hours, then 5 mg t.i.d. or q.i.d. as needed; adjunctively in skeletal muscle spasm, 2 to 10 mg t.i.d. or q.i.d.; adjunctively in convulsive disorders, 2 to 10 mg b.i.d. to q.i.d. **Geriatric or debilitated patients:** 2 to 2½ mg, 1 or 2 times daily initially, increasing as needed and tolerated. (See Precautions.)

Children: 1 to 2½ mg t.i.d. or q.i.d. initially, increasing as needed and tolerated (not for use under 6 months). **Supplied:** Valium® (diazepam) Tablets, 2 mg, 5 mg and 10 mg; bottles of 100 and 500. All strengths also available in "Tel-E-Dose"™ packages of 1000.

as acute hyperexcited states, anxiety, hallucinations, increased muscle spasticity, insomnia, rage, sleep disturbances, stimulation have been reported; should these occur, discontinue drug. Isolated reports of neutropenia, jaundice; periodic blood counts and liver function tests advisable during long-term therapy.

Please see last page of this advertisement for prescribing information.

Valium®
(diazepam)

2-mg, 5-mg, 10-mg tablets

ROCHE
Roche Laboratories
Division of Hoffmann-La Roche Inc.
Nutley, N.J. 07110

ROCHE
Roche Laboratories
Division of Hoffmann-La Roche Inc.
Nutley, N.J. 07110

Valium advertisement from 1971 targeted at women

presynaptic inhibition in the cat spinal cord (11). But this report went largely unnoticed because (1) the paper was published in German, (2) presynaptic inhibition was a relatively new phenomenon and not accepted by some neurophysiologists, and (3) the chemical transmitter involved in presynaptic inhibition was not known (1).

Sophisticated electrophysiological and biochemical methods were used in attempts to find the specific neurotransmitter mediating the benzodiazepines' effects on reducing arousal and alertness, preventing the physical responses to stress, and improving

sleep. But researchers found negligible effects on the dopamine, norepinephrine, serotonin, and acetylcholine systems (1).

In the early 1970s, it became clear that GABA, a biological compound known for many years and accepted as a transmitter in lower animals, was also a critically important inhibitory neurotransmitter in the mammalian nervous system (1). In some regions of the brain, 20-50% of synapses are mediated by GABA (3).

In an elegant series of experiments using electrophysiologic techniques, Willy Haefely at Roche demonstrated that the GABA synapse was the

In the public domain.

primary site of action of the benzodiazepines (1). Using biochemical methods, Erminio Costa independently arrived at the same conclusion. Further studies unequivocally demonstrated that the benzodiazepines amplify GABAergic transmission (1, 3).

The binding sites for benzodiazepines in the brain correlate with the drugs' pharmacological effects in virtually all brain regions. On the other hand, specific binding sites for benzodiazepines outside the brain and spinal cord do not exist, and this accounts for the virtual absence of direct benzodiazepine effects on peripheral tissues (1).

Researchers then began using the benzodiazepines as tools to elucidate the form and function of the GABAergic system, the most important "calming" neurotransmitter in the brain (3).

The benzodiazepines have also helped to establish animal behavioral models for assessing anxiety. It is now generally believed that the anxiolytic effect of drugs in humans correlates with inhibition of behaviors in animals in punishment or conflict tests (1). Many of the discoveries of brain function would not have been possible without the benzodiazepines (3).

Changing Times

Through the 1960s, the benzodiazepines' popularity rapidly increased, and they replaced most other sedatives and anxiolytics (2). Unlike all other psychotropic drugs, the benzodiazepines had a wide therapeutic index. Death from respiratory collapse simply did not occur with the benzodiazepines (3). Overdose would put people to sleep but they would wake up again in a relatively short time and fully recover.

The safety and efficacy led to a public perception that benzodiazepines were a simple answer to overcoming the stress and strain of daily life. In addition to well-defined anxiety disorders, indiscriminate prescription use became common among executives, housewives, and the elderly (3).

The drugs were also used recreationally. In 1966, the Rolling Stones released "Mother's Little Helper," a reference to this widespread prescribing and abuse (2). Contrary to the view of many at the time, the benzodiazepines are not happiness pills. They do not promote happiness; rather, they counteract the perception of stress (3).

By the late 1970s, it was becoming clear that benzodiazepines could cause problems, especially in situations in which they were never meant to be used and in which clinical trials had not confirmed their efficacy (3). The very potent sedative benzodiazepine, Rohypnol, became notorious as the "date-rape drug" (2).

This led, in the early 1980s, to publicity and anecdotal reports of benzodiazepine misuse and abuse, as well as unconfirmed toxicity (1, 2). Medical concern and media pressure spurred politicians and bureaucrats into action. The U.S. Senate held hearings, and federal regulators imposed restrictions. Doctors became more reluctant to prescribe benzodiazepines, even for patients who clearly needed them, and patients were reluctant to take them because of an unfounded fear of addiction (3).

Benzodiazepines can be abused, but mostly by people who have a history of abusing other drugs, particularly opioid- and alcohol-dependent individuals. Long-term use in any patient can also result in tolerance, dependence, and withdrawal symptoms. But interestingly, benzodiazepines are among the few drugs that alleviate the psychological and physical distress in patients withdrawing from narcotics in medical treatment programs (3).

Because of persistent concerns, benzodiazepine prescribing declined significantly in the 1990s, and investigators evaluated alternative classes of drugs to treat anxiety disorders. Unfortunately, none of those alternatives have the speedy onset of action of the benzodiazepines, and a large portion of patients are non-responders (3).

In the last two decades, benzodiazepine use has rebounded (12, 13). From 1996 to 2013, prescriptions for benzodiazepines increased 67% and the total quantity of the drug in filled prescriptions more than tripled (12). Adults aged 50-64 years are now the largest group using prescribed benzodiazepines, and the highest misuse is by young adults aged 18-25 years (13). Benzodiazepine misuse, which now accounts for nearly 20% of overall use, is still strongly associated with those who abuse and are dependent on opiates (13).

The concurrent increase in opioid prescriptions has created dangerous conditions for fatal overdosing. While the sedative effect of the

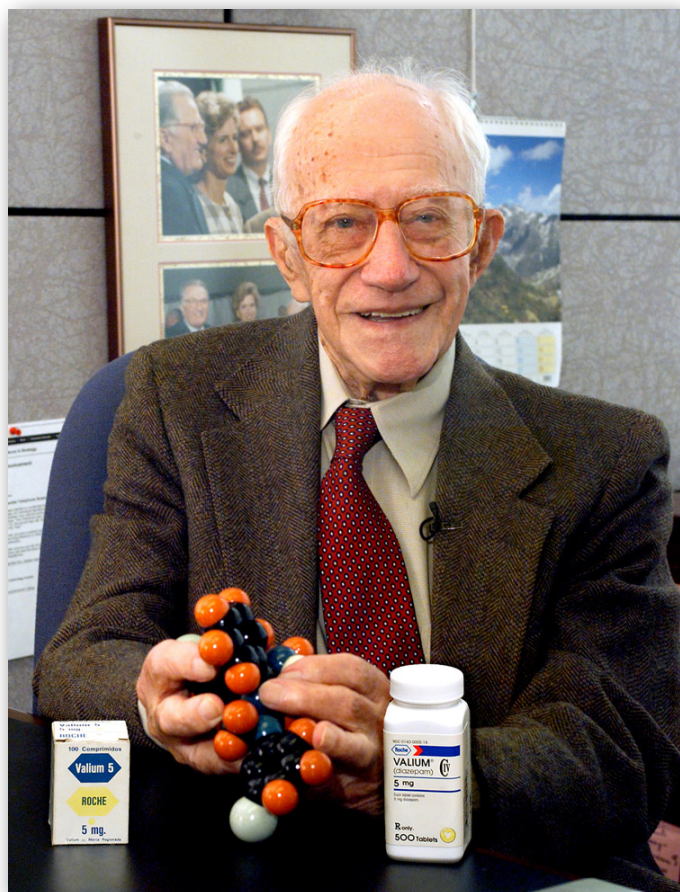

Reprinted with permission from F. Hoffmann-La Roche Ltd.

Leo Sternbach with molecule of Librium and bottle of Valium

benzodiazepines is limited and not life-threatening, it adds to the sedative effects (particularly respiratory depression) of other drugs. Studies have

found that concurrent use of a benzodiazepine with opiates increases the risk of overdose death 4-fold, compared to opioid use alone (12, 14, 15).

In 2016, the benzodiazepine alprazolam (Xanax®) was involved in 6,209 overdose deaths, making it the fifth most deadly overdose drug, behind fentanyl, heroin, cocaine, and methamphetamine (16). Diazepam and clonazepam also made the list, but the benzodiazepine deaths almost always involved concurrent opiate use. Because of this lethal synergy, the Centers for Disease Control and Prevention recommend that “clinicians should avoid prescribing opioid pain medication and benzodiazepines concurrently whenever possible” (14).

Despite real concerns over abuse and misuse, nothing has replaced the benzodiazepines for safe and effective treatment of anxiety and related disorders, when prescribed responsibly. And the World Health Organization continues to include diazepam in its Model List of Essential Medicines (3).

Roche’s Wunderkind

In his career, Leo Sternbach was directly responsible for 241 patents. When he retired from Roche in 1973, his discoveries contributed to almost one-fifth of all Roche patents in force at that time (3). He continued to report for work as a Roche consultant almost every day until 2003. And as recently as 1994, the products he patented accounted for 28% of the company’s worldwide pharmaceutical sales (9).

Benzodiazepines Discovered by Leo Sternbach

Introduction	Generic Name	Brand Name	Main Indication
1960	Chlordiazepoxide	Librium	Anxiolytic
1963	Diazepam	Valium	Anxiolytic, anticonvulsant
1965	Nitrazepam	Mogadon	hypnotic
1968	Medazepam	Nobrium	Long-acting anxiolytic
1973	Clonazepam	Rivotril, Klonopin	Anticonvulsant, panic disorder
1974	Bromazepam	Lexotan	anxiolytic
1975	Flunitrazepam	Rohypnol	Insomnia, surgical pre-medication
1978	Flurazepam	Dalmadorm, Dalmane	insomnia
1982	Midazolam	Dormicum, Versed	Surgical pre-medication

References

1. Haefely W (1983) Alleviation of anxiety – the benzodiazepine saga, in *Discoveries in Pharmacology: Psycho- and Neuro-pharmacology* (Parnham M J and Bruinvels J eds) pp 269-306, Elsevier, New York.
2. Dronsfield A and Ellis P (September 1, 2008) Librium and Valium – anxious times. Education in Chemistry; available from: <https://eic.rsc.org/feature/librium-and-valium-anxious-times/2020182.article>
3. Baenninger A, Costa e Silva JA, Hindmarch I, Moeller H-J, and Rickels K (2004) *Good Chemistry: The life and legacy of valium inventor Leo Sternbach*. McGraw-Hill, New York.
4. Berger FM (1954) The pharmacological properties of 2-methyl-2-n-propyl-1,3-propanediol dicarbamate (Miltown), a new interneuronal blocking agent. *J Pharmacol Exp Ther* **112(4)**: 413-423.
5. Hofmann K (1987) Biographical Memoir: Vincent du Vigneaud. National Academy of Sciences, Washington DC; available from: <http://www.nasonline.org/publications/biographical-memoirs/memoir-pdfs/du-vigneaud-vincent.pdf>
6. Sternbach LH (1979) The benzodiazepine story. *J Med Chem* **22(1)**: 1-7.
7. Randall LO, Schallek W, Heise GA, Keith EF, and Bagdon RE (1960) The psychosedative properties of methaminodiazepoxide. *J Pharmacol Exp Ther* **129(2)**: 163-171.
8. New way to calm a cat (April 18, 1960) *Life Magazine*, pp. 93-97; available from: https://books.google.com/books?id=NE8EAAAAMBAJ&pg=PA93&source=gbs_toc_r&hl=en#v=onepage&q&f=false
9. Oransky I (2005) Obituary: Leo H. Sternbach. *Lancet* **366(9495)**: 1430.
10. Goodkin HP and Kapur J (2009) The impact of diazepam's discovery on the treatment and understanding of status epilepticus. *Epilepsia* **50(9)**: 2011-2018.
11. Schmidt RF, Vogel ME, and Zimmermann M (1967) Die Wirkung von Diazepam auf die präsynaptische Hemmung und andere Rückenmarksreflexe. *Naunyn Schmiedebergs Arch Pharmacol Exp Path* **258**: 60-82.
12. Bachhuber MA, Hennessy S, Cunningham CO, and Starrels JL (2016) Increasing benzodiazepine prescriptions and overdose mortality in the United States, 1996-2013. *Am J Public Health* **106(4)**: 686-688.
13. Maust DT, Lin LA, and Blow FC. Benzodiazepine use and misuse among adults in the US. *Psychiatry Online* DOI 10.1176/appi.ps.201800321; available from: <https://ps.psychiatryonline.org/doi/10.1176/appi.ps.201800321>
14. Dowell D, Haegerich TM, and Chou R (March 18, 2016) CDC Guideline for prescribing opioids for chronic pain, *Morb Mortal Wkly Rep* **65(1)**: 1-49; available from: <https://www.cdc.gov/mmwr/volumes/65/rr/rr6501e1.htm>
15. Medicare (May 12, 2016) Concurrent use of opioids and benzodiazepines in a Medicare Part D population; available from: <https://www.cms.gov/Medicare/Prescription-Drug-Coverage/PrescriptionDrugCovContra/Downloads/Concurrent-Use-of-Opioids-and-Benzodiazepines-in-a-Medicare-Part-D-Population-CY-2015.pdf>
16. Hedegaard H and Bastian BA (2018) Drugs most frequently involved in drug overdose deaths: United States, 2011-2016. *Natl Vital Stat Rep* **67(9)**: 1-12; available from: https://www.cdc.gov/nchs/data/nvsr/nvsr67/nvsr67_09-508.pdf



The Pharmacologist,
Volume 61,
Number 1,
March 2019



Viagra from NO to Yes

Rebecca J. Anderson, PhD

At the annual meeting of the American Urological Association in 1983, Giles Brindley gave a presentation that few in the audience would ever forget. The evening symposium on April 18 was co-sponsored by the Urodynamics Society and held in the ballroom of the Hilton Hotel in Las Vegas. Very little was known at that time about the physiology of penile erection or safe and effective drug treatments, so the symposium was well attended (1).

The unstated but strictly followed dress code in those days was business attire at medical conferences. But when Brindley, the first speaker, walked to the podium, he was wearing a blue track

suit (2, 3). The accomplished British neurophysiologist began his talk with a series of 35 mm slides showing photos of a human penis in various stages from flaccid to full erection (1, 2). Brindley explained that injection of vasoactive drugs into the penis could induce an erection, as shown in some of the photos (2). In an era before selfies, Brindley announced that all of those photos were of his own penis. Gasps and muffled whispers rippled through the audience (1).

Then, to emphasize the point, Brindley moved to his left, turned sideways, arched his back, and pulled up his sweatpants tight around his genitalia (1, 2). He said, "It is in fact phentolamine that I've injected into

my corpus cavernosum today, and the erection that's pushed aside by my trousers at the moment is in fact now virtually full" (3). The whispers were no longer muffled (1).

More than a hundred urologists—many having brought their spouses—witnessed this demonstration, but the bulge in Brindley's pants was hard to see by those sitting beyond the first few rows of the large ballroom. Later, he said it was at the session chairman's request, but for whatever reason, Brindley lowered his sweatpants to reveal his clearly erect penis (1, 2, 4). The audience was shocked into silence. Then, "all chaos broke out" when Brindley stepped down from the speakers' platform (pants still lowered), walked through the aisles, and invited the audience to feel how firm his penis was (1, 2, 4).



Jimsonweed flower

Try, Try Again

Cultures throughout history have employed various means to facilitate erections on demand. Homer recommended the flowering jimsonweed. A 15th century European text claimed that witches caused impotence (by placing testicles of a cock under the bed) and said you could undo the hex by sprinkling the walls of your house with dog's blood and carrying around the bile of fish (3). Any efficacy from these remedies was pure coincidence.

The first report of an implanted device to treat impotence appeared in 1936. Nikolaj Bogoraz inserted human rib cartilage into the penises of impotent men (3, 5). This peculiar procedure derived from the observation that male walrus and some other

mammals have a permanent bonelike structure in their urethra that guarantees potency (3). Unfortunately for Bogoraz's patients, the cartilage implant could degrade over time, collapse on itself, and result in a permanently curved, nonfunctional penis (3, 5).

In the 1950s, investigators experimented with acrylic implants. This synthetic material could be molded and did not degrade, but few successes were reported (5).

Among the innovations spinning out of the space program in the 1960s was silicone rubber implants, and researchers determined that silicone was a satisfactory material for penile prostheses (5). Through trial and error, surgeons refined techniques and designs for implanted devices that performed physiologically and were not painful.

In 1973, F. Brantley Scott devised the first inflatable device made from silicone cylinders. In 1974, Michael Small and Hernan Carrion developed the first malleable silicone implant, subsequently called the Small-Carrion prosthesis. All of the currently available penile prostheses can be traced back to one of these two prototypes (5).

Drugs Work, Too

Despite these clinical innovations, as recently as the 1980s, surprisingly little research regarding penile mechanics had been conducted. Scientists



Ronald Virag

who studied sexual physiology received little respect from their colleagues and virtually no federal funding (3). The first significant advances resulted from serendipity and follow-up by a couple of astute researchers.

In 1982, Ronald Virag, a French cardiovascular surgeon, accidentally injected papaverine into the penile cavernosa of a patient during a surgical shunting procedure (6). The drug, a vascular smooth muscle relaxant, produced a fully rigid erection that lasted 2 hours.

Around the same time in London, Giles Brindley made a puzzling observation. Because electrical stimulation of pelvic nerves caused an erection,

Reprinted from https://commons.wikimedia.org/wiki/File:Dr._Ronald_Virag_working.jpg under the CC BY-SA 4.0

conventional wisdom asserted that smooth muscle contraction in the penis mediated the response (7). By this logic, Brindley reasoned that α -adrenergic blockers (which relax smooth muscle) would prevent an erection (7, 8). Instead, he found that phenoxybenzamine caused penile engorgement in 2 of 3 subjects.

Virag and Brindley both followed up on their unexpected observations with a series of methodical, well designed studies. Their results greatly enhanced the medical community's understanding of the mechanisms involved in penile erection. Virag recruited a series of impotent men for his studies (6). But Brindley experimented on himself, because he wanted to fully experience and understand the consequences before exposing other subjects to the same procedures (4).

Brindley made dozens of injections in the cavernosal space of his penis with various specific agonists and antagonists (9). His results confirmed that only α -adrenergic antagonists and direct smooth muscle relaxants mediated erection. Muscarinic receptors, for example, played no role, "despite many textbook statements that it is involved" (9).

Erections via drug-induced vasodilation seemed counterintuitive to Brindley, and he could only make educated guesses as to the mechanism. But he was satisfied that those drugs worked. He injected himself multiple times with α -adrenergic blockers to optimize the dose and his injection technique (7).

Extending his studies to 4 potent and 11 impotent men, Brindley demonstrated that the α -adrenergic blocker, phenoxybenzamine, "is of clear practical use, in that it causes prolonged full erection in some men with erectile impotence and allows them to have sexual intercourse" (7). He also made the insightful observation that when phenoxybenzamine or papaverine produced only a partial erection in impotent men, "sexual stimulation during this partial erection makes it complete" (9).

Brindley's unforgettable demonstration in Las Vegas revolutionized the treatment of impotence. Many of the attendees returned to their practices, confirmed Brindley's results, and began training impotent men to self-inject with papaverine or phentolamine. Without Brindley's "spectacular *tour de force*," they claimed, convincing the urology community to inject a drug to treat impotence "would have taken years if not decades to evolve" (1).

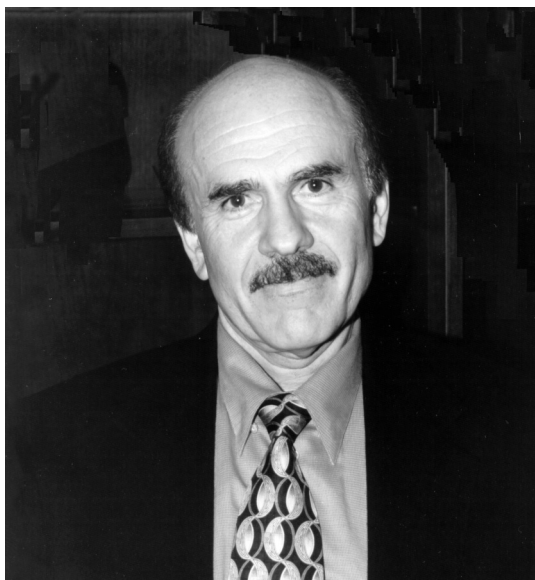

Louis Ignarro

Further insight regarding the physiology of penile erection came from Louis Ignarro, a pharmacologist, and Jacob Rajfer, a urologist, at UCLA. In 1988, they began a productive collaboration and found that sexual activity triggers release of the neurotransmitter, nitric oxide (NO), in the penis. NO increases production of cGMP, which relaxes vascular smooth muscle, dilates penile arteries, and enables erection (10). The enzyme, phosphodiesterase, rapidly degrades cGMP, and without sexual stimulation, the levels of cGMP remain very low, accounting for a flaccid penis.

Heartaches, Headaches

In the mid-1980s, five families of phosphodiesterases (PDE) had been characterized (11). These enzymes broke down cAMP, cGMP, or both. PDE 5 was present in vascular smooth muscle and platelets and appeared to be the only PDE that selectively degraded cGMP.

In 1986, Pfizer established a project team to find a PDE 5-specific inhibitor (11). Such a drug, they thought, should prevent angina attacks by dilating coronary arteries. Inhibiting platelet aggregation should also be beneficial, preventing thromboembolic heart attacks and strokes.

At the time, nitrates were the primary treatment for alleviating acute angina attacks. Drugs like nitroglycerin generate NO, which diffuses into the blood vessels, increases cGMP levels, causes coronary vasodilation, and improves blood flow to an ischemic heart. But the effect is short-lived, and tolerance to



Nick Terrett

nitrates develops quickly. The Pfizer researchers thought that blocking the breakdown of cGMP with a PDE 5 inhibitor would produce a longer-lasting therapeutic benefit (11).

Over the next 3 years, the team at Pfizer's European Research Centre in Sandwich, England, synthesized and tested 1,500 compounds (3). In December 1989, they produced UK-92,480, which proved to be a potent and selective PDE 5 inhibitor in their laboratory tests and animal models (11). After preclinical safety testing, the first Phase 1 trial was conducted in England in 1991. It was a single-dose safety study of UK-92,480, now called sildenafil (3, 11).

The second Phase 1 trial, a multi-dose study, began in early 1992 with healthy volunteers in South Wales. Sildenafil had a short half-life and was given orally 3 times daily for 10 days. The results were not promising (12). The subjects reported muscle aches and backaches at the doses that the researchers predicted would be needed to treat angina (3, 12).

Nevertheless, the project team moved ahead with the next trial—the first and only trial in angina patients. Sildenafil produced some mild beneficial effects on blood pressure and cardiac output but not the significant improvement in angina that the team expected (3, 11).

In parallel, Ian Osterloh, a manager at one of Pfizer's Phase 1 clinical units, conducted a small trial to determine the interaction between sildenafil and nitrates. When the two drugs were given together, healthy volunteers experienced a profound drop in

blood pressure (12). This posed a significant risk to angina patients, who might be exposed to both drugs, accidentally or otherwise.

The disappointing clinical results—on both safety and efficacy—greatly dampened enthusiasm for the drug. David Brown, a Pfizer chemist, recalled, “People weren't coming to the project team meetings—they all smelled failure” (13). At their quarterly project review meeting in June 1993, Pfizer's executives threatened to terminate the angina program.

Anything Else?

Days later, the team received some encouraging news. At the end of the multi-dose Phase 1 trial in Wales, the investigators asked the subjects an open question: Is there anything else you noticed during the trial? One Welsh miner put up his hand and said, “Well, I seemed to have more erections during the night than normal.” Some of the others smiled and said, “So did we” (13).

Reports of this sildenafil “side effect” did not come as a surprise to Peter Ellis and Nick Terrett, researchers in Pfizer's discovery lab at the Research Center in Sandwich. They were aware of the UCLA researchers' studies regarding the role of NO and cGMP in penile erection. In 1991, they had suggested that sildenafil, by inhibiting PDE 5 and increasing cGMP levels in the penis, might be useful in treating impotence (11).

Ellis and Terrett's scientific rationale, along with the Welsh miners' feedback, helped the Pfizer team to convince their senior managers to pursue this effect. They received executive approval for a pilot trial of sildenafil in impotent men. But designing the clinical protocol for this study posed several unique challenges.



Rigiscan instrument

First, they needed a way to measure the magnitude of each erection. Physicians had been using an instrument called RigiScan to differentiate patients with organic versus psychogenic impotence, by measuring penile rigidity while the patient slept. The Pfizer team decided that this measuring device would be suitable for their purposes as well (3).

Next, because NO release was mediated by nerve impulses that were activated by sexual stimulation, they knew that sildenafil would work only when subjects were sexually active. To get meaningful results, the team needed to standardize sexual stimulation. They decided that they would have the men view erotic videos and magazines while hooked up to the RigiScan device. However, laws in the UK at that time strictly regulated the use of sexually explicit materials. With some difficulty, the researchers managed to convince the British Home Office to grant a license for importing this material from Europe (3, 13).

Finally, the subjects needed to be in a quiet, relaxed setting—rather than the hubbub of a typical clinic. The investigators found a private hospital room in Bristol, England. The men took sildenafil 3 times daily for a week and then reported to the hospital for the RigiScan session (11). To ensure patient privacy, the sessions were scheduled in the evenings and on weekends (3).

Pfizer's management had authorized this trial reluctantly, and almost everyone thought that sildenafil wouldn't work (3). The erections in the Welsh miners had occurred after high doses, which also caused significant side effects. The dose chosen for this trial was much lower (to avoid adverse effects) and had never been associated with erections.

Despite everyone's concerns, the RigiScan measurements and feedback from the impotent men was very encouraging—they asked for more tablets. It confirmed that combining sildenafil with sexual stimulation was the key (3).

In all of the early studies, men took sildenafil 3 times a day (3). But to be practical as an impotence treatment, the drug needed to be reliably effective after a single dose—and work quickly.

In May 1994, the next Phase 2 trial, also conducted in Bristol, provided the proof the team needed. The double-blind, randomized, placebo-controlled crossover study enrolled 12 impotent men. A single dose of sildenafil induced erections while men were watching erotic videos. And the magnitude of the response (measured by RigiScan) was dose dependent (15).

By this time, Pfizer researchers had found PDE 5 in human corpus cavernosal smooth muscle (11, 16). They also showed fairly conclusively that sildenafil's mechanism of action in treating impotence “involves the potentiation of the NO-stimulated cGMP signal mediating relaxation of cavernosal smooth muscle during sexual stimulation” (16). “Ok,” Peter Ellis said, “this could really be something worth having” (3). Pfizer accelerated the clinical trial timetable (11).

Concurrently with these trials, the National Institutes of Health issued a consensus statement. A review panel said that the term “impotence” was confusing and often led to “uninterpretable results in both clinical and basic science investigations” (17). They suggested a more precise term, “erectile dysfunction,” be used instead.

Bedroom Data

The RigiScan device had provided quantitative data in a controlled environment, but the Pfizer team now faced another challenge. How could they show that the drug worked during unstructured activities—in the bedroom?

At the annual American Urological Association meeting in 1994, Ian Osterloh found a solution. He attended a poster session, where a urologist presented a sexual-function questionnaire that he was developing (3). Such a questionnaire might work for Pfizer's trials, if they could validate it.

The RigiScan device had provided quantitative data in a controlled environment, but the Pfizer team now faced another challenge. How could they show that the drug worked during unstructured activities—in the bedroom?

Back in Sandwich, Osterloh convened a team of internal and external experts. They wanted to develop relevant questions describing male sexual function that everyone could agree upon, regardless of culture and language (3, 19). The final product, called the International Index of Erectile Function (IIEF), consisted of 15 questions that seemed to be universally accepted and were grouped into 5 categories: erectile function, orgasmic function, sexual desire, intercourse satisfaction, and overall satisfaction (19).

Table 2 The IIEF-5 questionnaire^a

Over the past six months:					
	Very low	Low	Moderate	High	Very high
1 How do you rate your confidence that you could get and keep an erection?	1	2	3	4	5
2 When you had erections with sexual stimulation, how often were your erections hard enough for penetration?	Almost never/never	A few times (much less than half the time)	Sometimes (about half the time)	Most times (much more than half the time)	Almost always/always
3 During sexual intercourse, how often were you able to maintain your erection after you had penetrated (entered) your partner?	1	2	3	4	5
	Almost never/never	A few times (much less than half the time)	Sometimes (about half the time)	Most time (much more than half the time)	Almost always/always
4 During sexual intercourse, how difficult was it to maintain your erection to completion of intercourse?	1	2	3	4	5
	Extremely difficult	Very difficult	Difficult	Slightly difficult	Not difficult
5 When you attempted sexual intercourse, how often was it satisfactory for you?	1	2	3	4	5
	Almost never/never	A few times (much less than half the time)	Sometimes (about half the time)	Most times (much more than half the time)	Almost always/always
	1	2	3	4	5

^aThe IIEF-5 score is the sum of the ordinal responses to the five items; thus, the score can range from 5 to 25.

Reprinted with permission from Springer Nature. See (8).

IIEF-5 Questionnaire

The IIEF was pilot-tested on men with erectile dysfunction (ED) in the United Kingdom and Sweden and then linguistically validated in 12 countries in 10 languages. The questionnaire, and its simplified 5-question version, IIEF-5, have subsequently been accepted as the gold standard for assessing ED drugs in clinical trials, as well as for classifying ED severity and prevalence (11).

The first Phase 2 trial using the IIEF questionnaire began in September 1994, enrolling 351 ED patients in the UK, Sweden, and France. Men took one of three sildenafil doses or placebo daily at home for 4 weeks. In February 1995, Osterloh received the interim results, which showed “a beautiful dose-response on the IIEF questions in general and on the key question of whether sildenafil improved men’s erections” (3).

In December 1994, Pfizer started a second large Phase 2 trial in the UK, Norway, and France. This was an open-label dose-escalation trial, in which the men started with a 10 mg dose and were allowed to increase their daily dose stepwise if they were not helped by the lower dose. Most men settled on 100 mg as their preferred dose. They took the drug at home in conjunction with intercourse—on average, twice a week. After 16 weeks, they entered a “blind extension” of the trial and were randomized to either continue at their favored sildenafil dose or were given placebo. Those taking placebo rapidly returned to

their baseline erectile function—and many of them complained about it (3).

We Want More

Typically, at the end of early clinical trials, patients are expected to return their unused tablets. But the Pfizer team was receiving many letters requesting additional drug supplies after trial completion. Some men were quite insistent. One said, “This is like throwing a drowning man a life preserver and then pulling the plug out of it” (3).

So, Pfizer launched open-label extension trials and allowed patients from the Phase 2 trials to enroll. The extension trials benefitted everyone. The patients could receive sildenafil for an additional year, and Pfizer collected data on the drug’s long-term effects.

More Good News

All of the early clinical trials restricted enrollment to men whose ED was due to nonorganic (that is, psychological) causes. Then, in several small, specialized studies, RigiScan measurements showed that sildenafil was also effective in impotent men with diabetes and spinal cord injuries. In planning the pivotal Phase 3 trials, the team expanded enrollment to include the broadest possible range of ED patients. But Osterloh nearly left out radical prostatectomy patients, “because we thought—mistakenly, as it turned out—that there is no way that sildenafil is going to work for them” (3).

The Phase 3 trials began in late 1995 in the US, Canada, and Europe (20). Pierre Wicker, who managed Pfizer's American clinical trials, said, "We had more patients willing to participate than we could accept" (3). Those patients' responses confirmed and expanded the results of the earlier trials. Sildenafil was effective in more than 80% of the patients, regardless of the cause of their ED, and the erections reliably occurred about 25 minutes after taking the tablet (3, 20).

While the Phase 3 trials proceeded smoothly, some of the Phase 2 patients were nearing the end of their one-year open-label extensions. Again, Pfizer was deluged with letters, pleading for continued access to the drug. So, the Pfizer team added 3 more years to the open-label extension studies (3).

After clinical trials in more than 4,000 satisfied patients, the most commonly reported adverse events were headache and flushing (16% and 10%, respectively). In most cases, these effects were transient and mild (20, 21).

Because the Pfizer researchers had specifically designed sildenafil to dilate coronary arteries, a team of cardiologists carefully analyzed the data for signs of serious cardiovascular side effects. The incidence of heart attacks, strokes, and other cardiac events was no different between sildenafil- and placebo-treated patients (11, 21). Also, the patients did not experience hypotension or any adverse effects related to blood pressure, such as dizziness (3).

The broad range of patients recruited for the Phase 3 trials included many men with health problems (like hypertension and diabetes) that required drug

treatment. Fortunately, interactions between those drugs and sildenafil did not alter sildenafil's safety profile or vice versa (3).

There was one exception. As Osterloh had found in his drug-interaction study, the combination of nitrates and sildenafil causes a dangerously abrupt drop in blood pressure. For that reason, nitrates are one of the few contraindications for sildenafil (3, 11).

Another mechanism-related adverse effect of sildenafil was an effect on vision. As new families of PDEs were characterized, the Pfizer researchers systematically assessed sildenafil's effect on them. They found that sildenafil is a weak inhibitor of PDE 6, which is located exclusively in the retina and plays a role in phototransduction (11, 16, 22). Although the Pfizer team saw no eye toxicity in animals, they closely monitored the patients enrolled in the Phase 2 and 3 trials for effects on the eye. In addition, as a precaution, they excluded men with retinitis pigmentosa.

About 3% of the sildenafil-treated patients reported blue-tinged vision and an increased sensitivity to light, which seemed to correlate with inhibition of PDE 6 (1, 22). Fortunately, the men experienced no changes in color vision or visual function, even after long-term treatment. They might experience the visual effect when they took the drug, but it was always transient and did not affect their daily life (22).

A good indicator of sildenafil's efficacy and tolerability was that 90% of all patients in the clinical trials completed long-term treatment, and only 2% withdrew because of side effects (20, 21).

The Little Blue Pill

After 8 years of research, the Pfizer team had conducted 21 clinical trials in 13 countries involving nearly 4,500 men. And thanks to the open-label extensions, they had long-term safety data from some men who had been taking the drug for 3 years. On September 29, 1997, Pfizer representatives simultaneously hand-delivered a CD-ROM containing all of the accumulated data to both the U.S. Food and Drug Administration (FDA) and the European Medicines Agency (3).

FDA approved Viagra® (sildenafil citrate) on March 27, 1998. Within hours, Osterloh and other key investigators held a press conference announcing Viagra, the first oral drug approved for



Viagra tablets

the treatment of ED. For the next 4 months, Pfizer's switchboard was flooded with phone calls from the press, the public, and physicians (3).

Print and broadcast coverage, including cover stories in *Time* magazine and *Business Week*, reached an estimated 140 million Americans—greater media attention than any other drug in history. At the same time, former presidential candidate Senator Bob Dole appeared on *Larry King Live*. Dole, a radical prostatectomy patient, had participated in the Viagra clinical trials. He endorsed Viagra, saying it was “a great drug” (3). Pfizer seized on this public announcement and engaged Dole in an ED public awareness initiative and its ads for Viagra.

Pfizer's marketing department had made several strategic decisions. The product would be a little blue, diamond-shaped pill. They also decided to use the recently proposed term “erectile dysfunction,” rather than impotence, “to remove the social stigma” (13). Among the wide range of marketing materials, they developed educational brochures specifically for doctors, because medical schools had not trained them on how to raise the delicate topics of sexual function and ED with their patients (3).

Pfizer also invested considerable effort in preparing its sales force, because they anticipated Viagra would probably elicit jokes and off-color comments (3). The training was aimed at helping the sales staff become more comfortable talking about ED and ensuring that those conversations remained professional (13). One Viagra sales representative, Jamie Reidy, said Pfizer conducted hours of workshops and sexual harassment training, “especially for the female reps who were going to be talking about erections all day long” (13).

Television advertising was also a challenge. At the time, media regulations prevented Pfizer from running its Viagra ad before 11:00 pm. Jennifer Doebler, Pfizer's marketing director, had to “go and talk to every single network and make the case why they had to let the ad run before 11, when [our] target audience was awake and watching” (13).

A Blue Rocket

Prior to Viagra, less than 10% of ED patients had sought treatment. Those who did start treatment often stopped (3). Coincidentally, Viagra reached the market just as the baby boom generation was transitioning into middle age. More than any previous generation,

the boomers wanted to continue living youthfully and deflected aging labels. They invested heavily in their health, including treatment for ED, which affects more than half of all men aged 40-70 (3).

During the first 6 months of Viagra's availability, physicians wrote 5.3 million prescriptions for it—the most successful introduction ever for a US drug. Within 18 months, it had captured 90% of the market (3).

Every physician had stories to tell. Some extended office hours, including weekends, to accommodate the overwhelming demand. Some patients came in wearing a trench coat, hat, and sunglasses and refused to give their name. To avoid patient embarrassment, one doctor referred to it as Vitamin V. Another had a 90-year-old patient who unflinchingly came every 3 months for a urological checkup, despite being “absolutely fit as a fiddle.” He was simply coming to get another pack of Viagra samples (13).

Viagra unquestionably benefitted men, but the reaction among women was mixed. There were those like the woman who threatened to call off her wedding unless her fiancé (a participant in the clinical trials) could continue getting experimental sildenafil after the trial ended (3). But there were also wives who said, “I thought we were done with that” (13).

Changing Hearts and Minds

Before Viagra, the prevailing view among experts, including Masters and Johnson, was that virtually all cases of ED stemmed from psychological causes (3). The relationship between ED and depression is complex, but Viagra was effective in men who suffered from both. In fact, Viagra treatment not only alleviated ED but also often reduced the symptoms of depression (3).

Certainly, depression and anxiety are important factors. But the Viagra clinical trials confirmed that about 80% of ED cases are associated with underlying medical conditions like diabetes and hypertension, as well as physical damage from spinal cord injury or radical prostatectomy (3).

Urologists had conducted most of the Viagra clinical trials, because ED was considered a subspecialty of urology, and urologists administered treatment (i.e. surgical implants or penile drug injections). But the Viagra trials made it clear that physicians across the entire medical spectrum would be prescribing it. Many men who had avoided routine checkups were now visiting their doctors, asking for

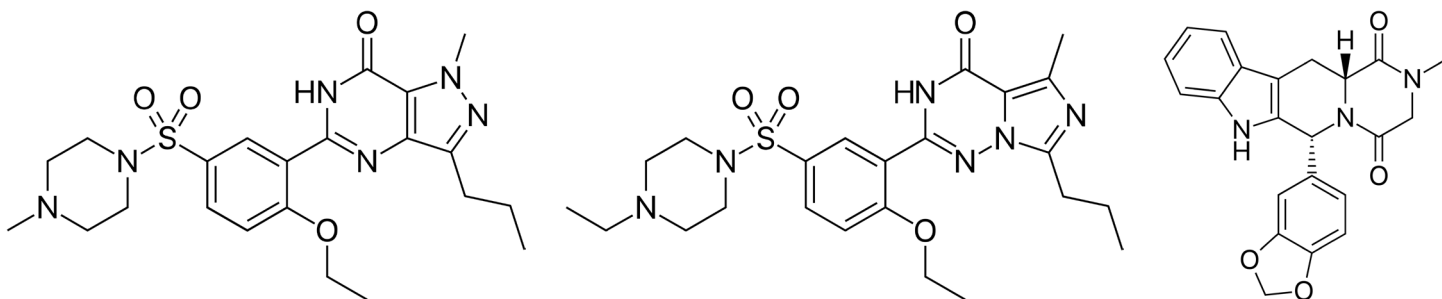

Chemical structure of sildenafil, vardenafil, and tadalafil

Viagra. Within a year, primary care physicians were writing 60% of all Viagra prescriptions (3).

Often, those patients' ED was actually an early sign of an underlying and potentially serious health condition. Atherosclerosis, for example, is the most common cause of organic ED. The narrow vessels of the penis are more sensitive to blockage than the larger heart vessels, making ED one of the first symptoms of cardiovascular disease.

Other contributing conditions include diabetes, hypertension, alcohol, cigarette smoking, and some drugs (such as antidepressants, antihistamines, and opioids) (3). Viagra played a broad role in improving men's health, because it brought men to the doctor's office. Physicians could detect serious diseases earlier, and in many cases, treatment of those diseases alleviated ED without Viagra intervention.

Viagra does not affect sperm motility or morphology. It therefore assisted couples who wanted to start a family. It was especially helpful for young men with diabetes, spinal cord injury, or depression (3).

Viagra also tempted entrepreneurs. According to a recent FDA survey, 776 dietary supplement products contain undeclared but potent drugs. Sildenafil is the mystery drug most commonly missing from the label of over-the-counter products for sexual enhancement (23).

Another creative use was in US intelligence. Afghan warlords and tribal leaders expected to be paid for their cooperation, but cash and weapons were not always the best bribes. Showy gifts brought unwanted attention and might get the informant killed. Rather, the CIA sought to meet an informant's personal needs without leaving a visible trace (24). The long list of personalized incentives included surgical and dental services for the informant or his family. For older tribal leaders, intelligence operatives could dangle another enticement.

One CIA officer, for example, had tried in vain to win the cooperation of a 60-year-old Afghan chieftain, who had

extensive knowledge of the region but was cautious about engaging with the Americans. Finally, the intelligence operative pulled out 4 blue pills and said, "Take one of these. You'll love it." Four days later, the operative returned and the chieftain rushed up to him, beaming. "After that, we could do whatever we wanted in his area" (24).

Culture Shift

USA Today called Viagra "the little blue tablet that triggered a sexual revolution" and said that "life... will never be the same" (25). "Erectile dysfunction" entered the mainstream, going from a taboo topic—unmentioned even in the bedroom—to a legitimate medical disorder (13). Research of sexual function intensified and yielded a better understanding of erectile physiology and the underlying causes of ED. Pharmaceutical researchers produced several new oral drugs: tadalafil (Cialis®) and vardenafil (Levitra®).

Viagra also launched a thousand bad jokes and became a recurring topic of late-night television monologues—just one more sign of the profound shift in our culture (13). Male sexuality is now openly discussed, flashy ads for ED drugs are commonplace, and diseases in men are detected earlier.

In 1998, pharmacologist Louis Ignarro received the Nobel Prize in Physiology or Medicine for his discovery of NO's role in human physiology, including its role in facilitating erections. He called Viagra, a logical extension of his research, "one of the most novel and long-needed drugs in history" (3).

Giles Brindley, now 93 years old, has had a long and distinguished career in neurophysiology, conducting innovative research of visual, genitourinary, and sexual function (4). He also excelled in mechanical engineering and produced neurosurgical devices for spinal cord injury patients. A beloved mentor, Brindley inspired many young researchers, arranged their

funding, and provided vital guidance (27). In 1965, he was elected a Fellow of the Royal Society, Britain's highest honor for scientists. He was also knighted for his work in bioengineering (4, 27).

Although his methods were often unconventional, Brindley's passion and attention to detail led to many major research contributions and therapeutic milestones—none more memorable or impactful than his demonstration in Las Vegas. It was summed up best by Alvaro Morales, a urologist at the Las Vegas meeting and who later conducted some of the Viagra clinical trials: "The field was thrown wide open...the physiology and pharmacology of the erectile process became understood. New drugs were developed... Humanity owes a great deal of gratitude to Giles Brindley's brilliant mind (and to his penis)" (1).

*Gladly I think of the days
When all my members were limber,
All except one.
Those days are certainly gone.
Now all my members are stiff,
All except one.
—Goethe*



Reprinted with permission from Taylor & Francis Ltd, www.tandfonline.com on behalf of The Neurosurgical Foundation. See (26).

Giles
Brindley

References

1. Goldstein I (2012) The hour lecture that changed sexual medicine—the Giles Brindley injection story. *J Sex Med* **9(2)**: 337-342.
2. Klotz L (2005) How (not) to communicate new scientific information: A memoir of the famous Brindley lecture. *BJU Int* **96(7)**: 956-957.
3. Katzenstein L (2001) *Viagra (SildenafilCitrato): The Remarkable Story of the Discovery and Launch*. Medical Information Press, New York.
4. Kan J, Aziz TZ, Green AL, and Pereria EAC (2014) Biographical sketch: Giles Brindley, FRS. *Br J Neurosurg* **28(6)**: 704-706.
5. Le B and Burnett AL (2015) Evolution of penile prosthetic devices. *Korean J Urol* **56**: 179-186.
6. Virag R (1982) Intracavernous injection of papaverine for erectile failure. *The Lancet* **320(8304)**: 938.
7. Brindley GS (1983) Cavernosal alpha-blockade: A new technique for investigating and treating erectile impotence. *Brit J Psychiat* **143**: 332-337.
8. Brindley GS (1983) Cavernosal alpha-blockade and human penile erection. *J Physiol* **342**: 24P.
9. Brindley GS (1986) Pilot experiments on the actions of drugs injected into the human corpus cavernosum penis. *Br J Pharmacol* **87**: 495-500.
10. Rajfer J, Aronson WJ, Bush PA, Dorey FJ, and Ignarro LJ (1992) Nitric oxide as a mediator of relaxation of the corpus cavernosum in response to nonadrenergic, noncholinergic neurotransmission. *New Engl J Med* **326(2)**: 90-94.
11. Osterloh IH (2004) The discovery and development of Viagra® (sildenafil citrate), in *Milestones in Drug Therapy* (Dunzendorfer U ed) pp 1-13, Birkhäuser, Boston.
12. Osterloh I (April 27, 2015) How I discovered Viagra. *Cosmos*; available from: <https://cosmosmagazine.com/biology/how-i-discovered-viagra>.
13. Tozzi J (December 11, 2017) The little blue pill: an oral history of Viagra. *Bloomberg*; available from: <https://www.bloomberg.com/news/features/2017-12-11/the-little-blue-pill-an-oral-history-of-viagra>.
14. Schmid DM, Hauri D, and Schurch B (2004) Nocturnal penile tumescence and rigidity (NPTR) findings in spinal cord injured men with erectile dysfunction, *Int J Impot Res*, **16**: 433–440.
15. Boolell M, Gepi-Attee S, Gingell JC, and Allen MJ (1996) Sildenafil, a novel effective oral therapy for male erectile dysfunction. *Br J Urol* **78**: 257-261.
16. Ballard SA, Gingell CJ, Tang K, Turner LA, Price ME, and Naylor AM (1998) Effects of sildenafil on the relaxation of human corpus cavernosum tissue in vitro and on the activities of cyclic nucleotide phosphodiesterase isoenzymes. *J Urol* **159(6)**: 2164-2171.
17. Droller MJ, Anderson JR, Beck JC, Bremner WJ, Evans K, Gray M, Keeney AH, Lanzisera PJ, Liao WC, Richardson DW, et al. (December 7-9, 1992) Impotence: NIH consensus development conference statement; available from: <https://consensus.nih.gov/1992/1992Impotence091html.htm>

18. Rosen RC, Cappelleri JC, Smith MD, Lipsky J, Peña DM (1999) Development and evaluation of an abridged, 5-item version of the International Index of Erectile Function (IIEF-5) as a diagnostic tool for erectile dysfunction, *Int J Impot Res*, **11**: 319-326.
19. Rosen RC, Riley A, Wagner G, Osterloh IH, Kirkpatrick J, and Mishra A (1997) The international index of erectile function (IIEF): a multidimensional scale for assessment of erectile dysfunction. *Urology* **49(6)**: 822-830.
20. Goldstein I, Lue TF, Padma-Nathan H, Rosen RC, Steers WD, and Wicker PA (1998) Oral sildenafil in the treatment of erectile dysfunction. *New Engl J Med* **338(20)**: 1397-1404.
21. Morales A, Gingell C, Collins M, Wicker PA, and Osterloh IH (1998) Clinical safety of oral sildenafil citrate (VIAGRA™) in the treatment of erectile dysfunction. *Int J Impot Res* **10**: 69-74.
22. Laties AM and Fraunfelder FT (1999) Ocular safety of Viagra, (sildenafil citrate). *Trans Am Ophthal Soc* **97**: 115-128.
23. Tucker J, Fischer T, Upjohn L, Mazzera D, and Kumar M (October 12, 2018) Unapproved pharmaceutical ingredients included in dietary supplements associated with US Food and Drug Administration warnings. *JAMA Netw Open* **1(6)**: e183337; available from: <https://jamanetwork.com/journals/jamanetworkopen/fullarticle/2706496>.
24. Warrick J (December 26, 2008) Little blue pills among the ways CIA wins friends in Afghanistan. *The Washington Post*; available from: <http://www.washingtonpost.com/wp-dyn/content/article/2008/12/25/AR2008122500931.html?noredirect=on>.
25. Rubin R (March 17, 1999) First anniversary provides potent cause to celebrate. *USA Today*.
26. Kan J, Aziz TZ, Green AL, and Pereira EAC (2014) Biographical sketch: Giles Brindley, FRS, *Br J Neurosurg*, **28**:6, 704-706.
27. Showalter A (January 17, 2017) But, who is Giles Brindley? AllanShowalter.com; available from: <https://allanshowalter.com/2017/01/17/but-who-is-giles-brindley>.



The Pharmacologist,
Volume 61,
Number 2,
June 2019

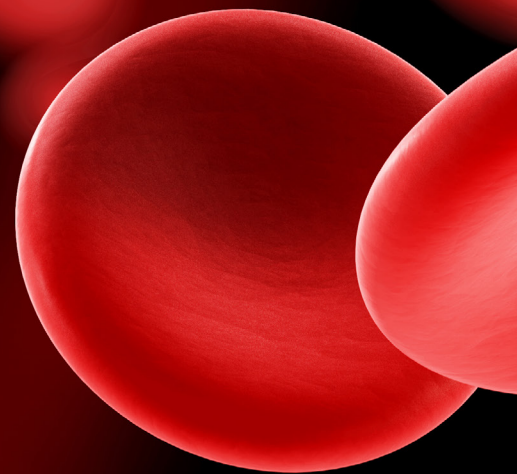

The Discovery and Development of Heparin

Rebecca J. Anderson, PhD

In December 1948, Jay McLean shipped his laboratory notebooks and accumulated reprints to Charles Best in Toronto. The research of medical students is rarely worth archiving, and McLean had difficulty finding a permanent home for his papers (1,2). But, given his own research, which overlapped and greatly extended upon McLean's findings, Best agreed to preserve the documents. Or, maybe, the ever-gracious Best just wanted to get McLean off his back.

Jay McLean grew up in San Francisco and was 15 years old when the great 1906 earthquake destroyed his family's home and his stepfather's place of business (3). He attended UC Berkeley and, after his sophomore year, could have entered medical school at UC San Francisco, as his father and uncle had done. Instead, Jay wanted to go to Johns Hopkins, because at that time, Hopkins was the best medical school in the country for training clinical researchers (3).



Jay McLean

Reprinted with permission from US National Library of Medicine

McLean faced a dilemma. His stepfather was willing to support his medical education in California. But entrance to Hopkins required one more year of undergraduate coursework, and McLean's stepfather was unwilling to finance his third year at Berkeley, as well as the transcontinental expenses to and at Hopkins (3).

So, to pay for his continued education, McLean spent 15 months working in the Mojave Desert gold mines. While completing his final year at Berkeley, in which he took the first-year medical student curriculum, McLean held various part-time jobs. At the college infirmary, he learned to perform urinalyses

and blood counts. But he was most fascinated by his physiology coursework and decided “I wanted to do some research there” (3).

When he received his bachelor of science degree in May 1914, McLean applied to Johns Hopkins, but his funds were depleted. He worked for 15 months drilling oil wells because “manual labor paid so much more than white collar jobs and living costs were lower” (3). The earnings were sufficient for a transcontinental train ticket and one year of medical school.

In the fall of 1915, despite receiving notification that he had not been accepted at Hopkins, McLean traveled to Baltimore anyway. He reasoned that he could work there as well as he could in California. In the meantime, Hopkins had added organic chemistry laboratory as a medical school admissions requirement. He could take that course at Hopkins’ undergraduate campus—but not while working in the oil fields (3).

Upon arrival, McLean immediately went to the medical school campus at Hopkins and introduced himself to the dean and registrar. Both of them confirmed that he had not been admitted. But the next day, the dean unexpectedly sent for him and offered a seat, due to a last-minute dropout in the second-year class (3).

McLean then went to see William Henry Howell, the head of the Johns Hopkins Physiology Department. He wanted to train under Howell, who was considered one of the best physiologists in the country. Because his funds would last only through the academic year, McLean asked for a project that he could complete by himself in that time, and his aim was publishable results.

The Calm Crusader

A native of Baltimore, William Howell had earned his bachelor’s and PhD degrees from Johns Hopkins. His doctoral thesis in 1884 was entitled, “The Origin of Fibrin Formed in the Coagulation of Blood” (2). After brief faculty positions at the University of Michigan and Harvard, he was invited back—at age 33—to chair the physiology department in the newly established Johns Hopkins Medical School (2, 4).

Although small in stature, Howell was a giant among physiologists (2). He had written America’s most widely used medical school textbook on physiology, which went through 14 editions in his lifetime. From 1899 to 1911, he served as the medical school dean, in



In the public domain

William Henry Howell

parallel with his teaching responsibilities and his ongoing research program.

Howell had an unhurried style and spoke with a calm, clear command of English (4). His lectures, which were usually accompanied by experimental demonstrations, were often judged the most popular by Hopkins medical students.

Likewise, he delivered numerous invited professional addresses without notes, enunciating sound ideas, logically, clearly, and in simple terms (4).

The same calm, factual style characterized his approach to research. He eschewed grandstanding researchers who competed with each other to produce results just to attract attention (4). Howell’s only motive was to add something new to the state of physiological knowledge, and he was in no rush to do it. Humble and self-effacing, he had no expectation of making any great discoveries, but his contributions were noteworthy and widely acknowledged.

His early research interests were broad, encompassing physiologic studies of nerve conduction, blood flow to the brain, electrolyte balance, and pituitary function. After 1909, Howell conducted research almost exclusively on the topic of his doctoral studies: hemostasis and blood pathology (4, 5).

In 1910, he isolated thrombin (1). In 1912, he established the potent blood clotting activity of cephalin, a substance he extracted from dog brain tissue (4). At the time, cephalin was classified as a phosphatide (now called phospholipid).

An Unexpected Result

When McLean arrived in September 1915, Howell was using cephalin as a tool in his blood clotting experiments. Unfortunately, the cephalin extract was a relatively crude mixture, and it completely degraded in about 3 months, despite air-tight storage (3).

McLean’s assignment was to prepare cephalin in a pure crystalline form, separated from the other substances in the extract. Then, he was to establish definitively whether purified cephalin or one of the extract’s other fractions was responsible for the clotting action (3).

Along with his research project, McLean took an organic chemistry lab course (to satisfy his missing admissions requirement). He also took an advanced course in German so that he could read more about lipids in German chemistry journals (3).

Howell directed a large research group, but that year he spent most of his time in a darkroom peering through a microscope to watch the formation of fibrin precipitates. McLean worked largely unsupervised across the hall. His workspace was “a sink and attached table-drainboard with a shelf over the sink” in an unused physiology student laboratory (3).

Through conscientious effort, including many nights and weekends, McLean completed the first part of his research in December 1915. Unfortunately, he was unable to crystallize cephalin.

While reading the German literature, McLean found articles by Erlandsen and Baskoff, who described procedures for extracting phosphatides from the heart and liver, respectively. McLean thought it might be easier to crystallize cephalin from extracts of those organs, because they have less lipid than the brain. Howell was not familiar with Erlandsen or Baskoff’s work, but he allowed McLean to try (3). McLean successfully extracted cephalin from both heart and liver, and it had the same clotting property as the original brain extract (2, 6).

Following Erlandsen’s procedure, McLean was also able to isolate from heart tissue the phosphatide that Erlandsen called cuorin (7). And following Baskoff’s procedure, he isolated the substance Baskoff

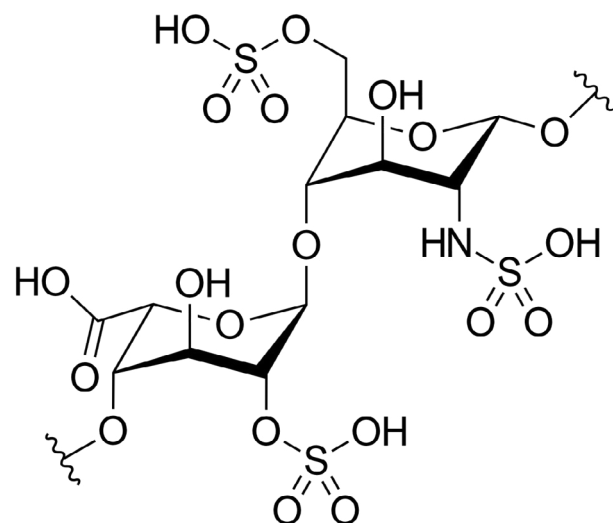

Skeletal formula of heparin

called heparphosphatide from the liver (8). These phosphatides had solubilities only slightly different from that of cephalin, but their clotting activity had never been tested (2).

McLean noted similarities between cuorin and heparphosphatide and suspected that they were the same substance. Furthermore, and to his surprise, they were both powerful anticoagulants (2, 6).

At first, he said nothing to Howell. Finding an anticoagulant was not part of his assigned project, and he needed to be certain of his results. He tested his extracts again and again, and by March 1916, “I was satisfied that an extract of liver (more than heart) possessed a strong anticoagulant action” (3).

He went to Howell and confidently announced, “I have discovered anti-thrombin” (3). Howell was skeptical. So, McLean stirred a batch of the liver extract, “heparphosphatide,” into a small beaker of fresh cat blood, placed it on Howell’s lab bench, and asked Howell to tell him when it clotted. “It never did clot” (3).

The Momentous Compromise

At the end of the academic year, McLean published his findings. He reported that cephalin, which he purified by several different methods, was indeed a substance that clotted blood (6).

McLean wanted to include his observations on the anticoagulant properties of “cuorin” and “heparphosphatide” in his paper, too. But Howell disagreed, because those results were preliminary. He said McLean’s experiments should be repeated and, if the anticoagulant property was confirmed, published

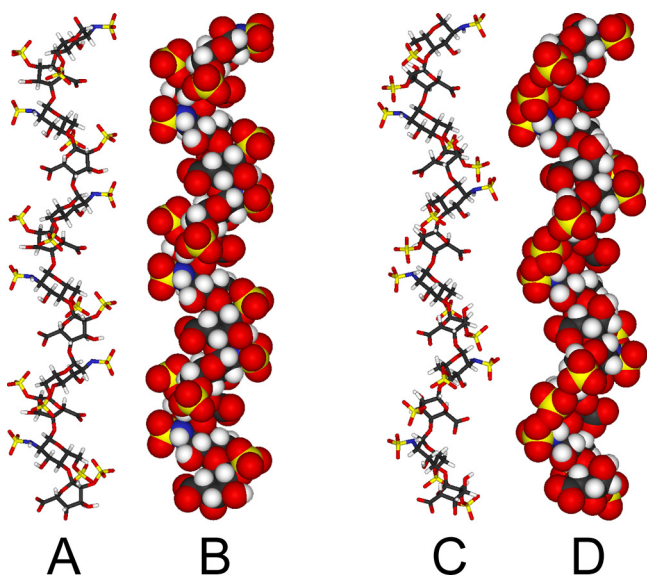

3D Structure of Heparin

in a standalone article (2). They compromised. McLean's anticoagulant observations were included in the body of his cephalin paper, but not mentioned in either the title or conclusions (6).

The important point is that this was the first time any substance with anticoagulant properties was reported in the scientific literature. Unfortunately, McLean's savings were now depleted again.

The Department of Research Medicine at the University of Pennsylvania offered McLean a fellowship, and he moved to Philadelphia, where he resumed his work purifying cephalin (1, 2, 9). At the end of the academic year, he published further results on cephalin and received his MS degree (2).

For the next 6 months, McLean served in the Ambulance Corps in France, returning in October 1917 to begin his third year of medical school at Johns Hopkins. He graduated in 1919 and served his surgical internship and residency at Johns Hopkins Hospital (1, 2). After two years studying in Europe, McLean took a surgical position at Presbyterian Hospital in New York City and then entered private practice (2).

Doing the Hard Work

Meanwhile, Howell undertook the hard work of isolating and purifying McLean's anticoagulant phosphatide. Assisted by another medical student, L. Emmett Holt, Jr., Howell used various extraction methods to improve on McLean's procedure (2, 5, 9).

In April 1917, Howell described the properties of his first purified substance at a Harvey Lecture in New York (2, 10). He acknowledged that isolation of the substance, which he called "antiprothrombin," followed directly from McLean's initial observations.

In October 1918, Howell and Holt published their now-classic paper announcing an anticoagulant phosphatide (10). They had found the substance in various tissues, but it was most abundant in the liver. Howell named it heparin, from the Latin *hepar* (liver). McLean's contribution was again acknowledged.

Howell and Holt's extraction method, "although time consuming and expensive in material, yielded a reliable preparation of heparin" (10). One milligram of heparin would prevent clotting of 1 ml of cat blood for 24 hours (2). This became the standard unit of anticoagulant potency for comparing early extracts.

The "heparphosphatide" prepared by McLean in 1916, the "antiprothrombin" reported in Howell's Harvey Lecture in 1917, and the heparin named by

Howell and Holt in 1918 were obtained by different extraction techniques. They were similar substances but likely not identical to each other (2).

For the next decade, until his retirement in 1930 at the age of 70, Howell, working alone, continued to tweak his extraction and purification procedures. He called each of these new products heparin, which would cause future controversy and confusion (2). For example, in 1923, he changed from ether to aqueous extraction and obtained a new "heparin" with a potency five times greater than the heparin produced in 1918 (1, 2).

Howell licensed this 1923 method to Hynson, Westcott & Dunning, a pharmaceutical company in Baltimore (1, 2, 5). The heparin produced by this method was not intended for clinical use, but rather as an aid to researchers who needed an effective anticoagulant for their laboratory studies (1, 2). Hynson, Westcott & Dunning continued to market heparin internationally until the mid-1930s, sticking with Howell's 1923 method (2, 5, 9). But Howell continued to make improvements. He was not a trained chemist and admitted, "I'd get along faster if I got an expert organic chemist, but it is more fun to do it myself" (4). In 1925, he reported a purer heparin, which was 40-fold more potent than his original 1918 material. And he was enough of a chemist to determine that this substance contained no phosphorus and therefore was not a phosphatide (2, 11). Nevertheless, he still called it heparin (12, 13). And he was quick to point out that this extract still contained not only heparin but also "inert materials of various kinds" (11).

Howell published his last paper on heparin in 1928. This final extract had a potency 50- to 100-fold greater than the 1918 material. He reported that it was a complex carbohydrate containing sulfur—a substance that came close to heparin's actual chemical composition (2).

Disappointing Therapeutics

By this time, Howell recognized the potential clinical value of heparin as a therapeutic treatment for coagulation disorders (9). Although no patient at Johns Hopkins Hospital was directly injected with his carbohydrate, it was used as an anticoagulant in blood that was transfused into six patients. Unfortunately, two of them developed toxic reactions (1, 2).

In 1924, Edward Mason at the Henry Ford Hospital in Detroit had used heparin from Hynson, Westcott, &

Dunning for blood transfusions (2, 5). Those patients also experienced adverse reactions (headaches, fevers, and nausea) (9). Howell was concerned that toxic contaminants would prevent widespread acceptance of heparin, and that concern drove his extensive efforts to purify the substance (5, 9).

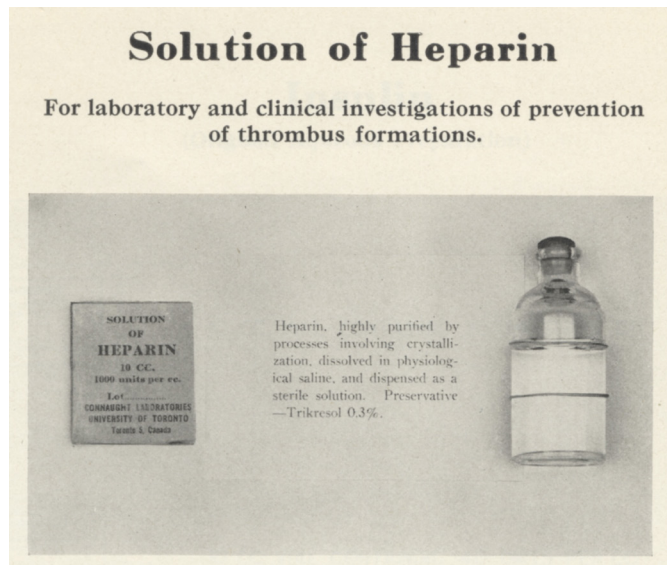

Heparin produced by Connaught Laboratories

Reprinted with permission from: Sanofi Pasteur Canada (Connaught Campus) Archives, Toronto.

Progress in Toronto

About the same time, Charles Best was thinking about his next big project. He was already famous. While still a master's degree candidate at the University of Toronto, Best had assisted Frederick Banting with isolating and characterizing insulin. When Banting was awarded the Nobel Prize in 1923, Best was a medical student and director of insulin production at Connaught Laboratories, a non-profit research unit of the University of Toronto (14, 15).

In 1925, Best graduated from the University of Toronto Medical School, and as valedictorian, was awarded the Ellen Mickle Fellowship (15). He elected to use the fellowship for postdoctoral research under Henry Dale, head of the National Institute for Medical Research, in London (9, 15).

In Dale's lab, Best encountered annoying problems with blood clotting in his glassware, because "...the crude heparin available was practically useless, and I made up my mind that on return to Toronto I would organize a group and tackle this problem" (2).

Best was awarded a DSc from the University of London and returned to the University of Toronto as

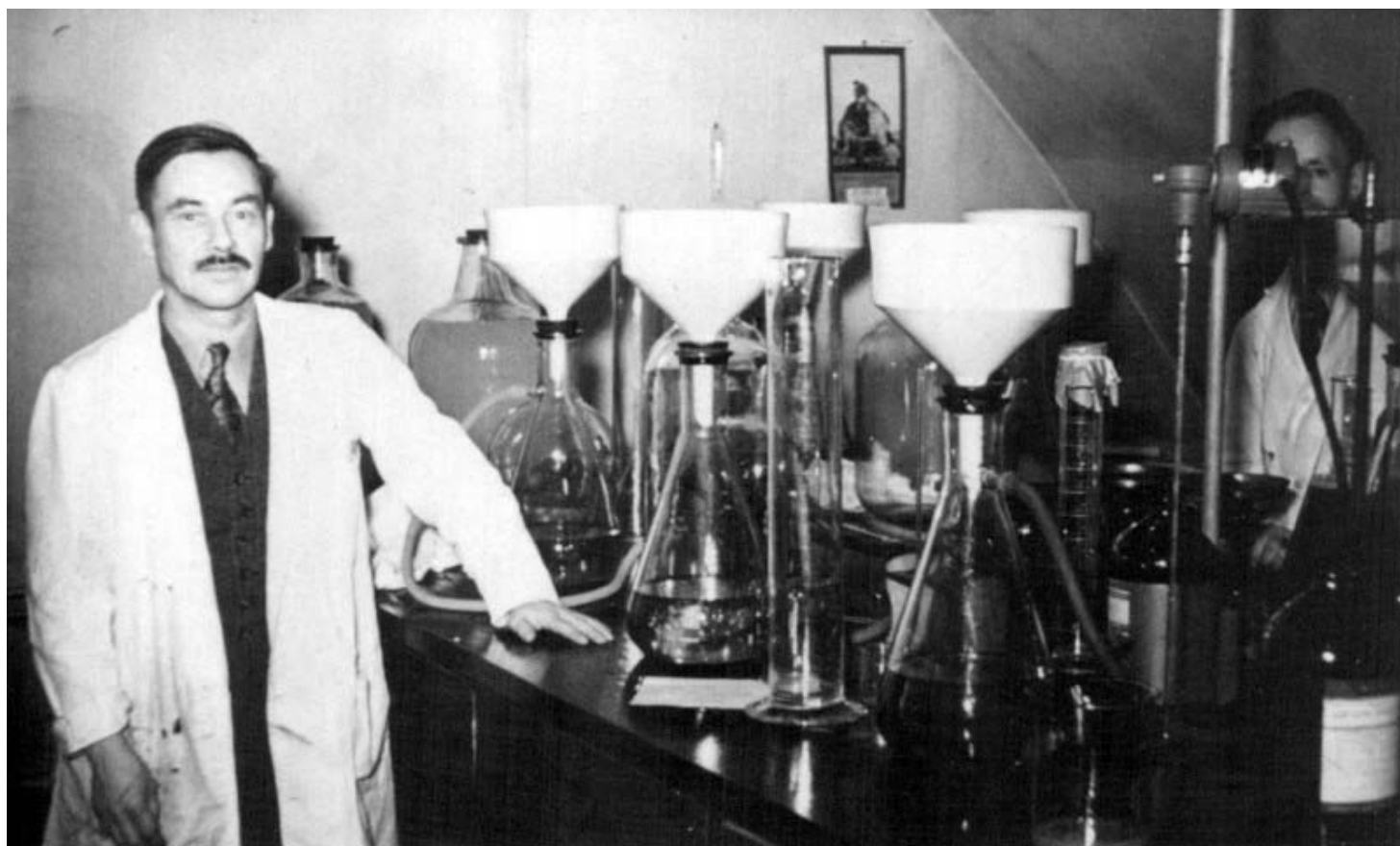

Arthur Charles in his laboratory at Connaught Laboratories

Reprinted with permission from: Sanofi Pasteur Canada (Connaught Campus) Archives, Toronto.



Reprinted with permission from: Sanofi Pasteur Canada (Connaught Campus) Archives, Toronto.

Production of heparin at Connaught Laboratories, 1949

head of the physiology department in 1929 (15). He envisioned he could advance the heparin field in a manner similar to insulin, with which he had extensive experience (9). Best and a young organic chemist, Arthur Charles, conducted some preliminary studies in the physiology department laboratories.

Then, Best (as assistant director of Connaught Laboratories) arranged for Arthur Charles to work with David Scott, a chemist with extensive experience in insulin production at Connaught Laboratories (14). Going forward, all of Charles and Scott's work on heparin tapped the funds, resources, and equipment at Connaught Laboratories, which were far superior to those available to Howell (2).

Charles and Scott switched from dog to cow liver, which was readily available from local slaughterhouses. In 1933, they published greatly improved methods for preparing and purifying heparin (9, 14). Because of the high cost of cow liver (demand was growing from the pet food industry), Charles and Scott explored other tissues. They found high amounts of heparin in muscle,

intestines, and lung, as well as in liver (5, 13, 14). In fact, the only tissue that contained little or no heparin was blood (5).

Cow lung provided a cheap source of material, and by 1934, they were processing more than 400 pounds of cow lung daily for the extraction of heparin (2). The work was highly complex and unpleasant, because the tissues had to decay naturally before extraction and purification. This smelly process forced them to move their work from downtown Toronto to Connaught's Dufferin "Farm" on the outskirts of the city (14).

By 1936, Charles and Scott had crystallized the sodium salt of heparin, and it was free of the toxic components that had plagued earlier extractions (2, 5, 13). With some effort, they were able to produce a product with a consistent anticoagulant potency, 100-times greater than the product marketed by Hynson, Westcott & Dunning (2, 5, 14).

Best kept Howell informed of the Toronto group's progress. He intended to produce heparin at Connaught Laboratories for sale (2, 9). Howell encouraged those efforts, expressing frustration that

Hynson, Westcott & Dunning had resisted improving its process. He was concerned that the U.S. company might stop production of the expensive product altogether (2, 9).

The availability of Connaught Laboratories' pure, well-standardized heparin greatly accelerated the pace of experimental studies (9). Researchers around the world requested samples.

Physiological Characterization

Leading those experimental efforts was Best's team in Toronto. His coworkers included Louis Jaques (a physiology graduate student), Gordon Murray (a surgeon at Toronto General Hospital), and T. S. Perrett (a surgical fellow at Toronto General).

In 1938, they reported that heparin completely prevented blood from clotting for up to 24 hours as it circulated through tubing—an observation of critical importance to the development of hemodialysis and cardiopulmonary bypass operations (2).

Murray, an expert in vascular surgery, developed lab methods for inducing controlled vascular trauma and blood clotting in vivo. In elegant experiments in dogs, he used this technique to demonstrate the unquestionable value of heparin in preventing arterial and venous thrombosis (2, 5, 9). This opened the way for Murray's pioneering surgical management of arterial disease in patients (2).

The Swedish Connection

Shortly after Best returned to Toronto in 1929, Erik Jorpes, a Swedish physiologist, visited Connaught Laboratories to observe insulin production. During the visit, Best also introduced him to the work on heparin (5).

When Jorpes returned to the Karolinska Institutet in Stockholm, he began his own efforts to isolate and characterize heparin (5, 12, 13). In 1935, he published his findings. Researchers had already determined that heparin was a polysaccharide, consisting mainly of repeating disaccharide units. Jorpes, among other things, established that this polysaccharide contains a high proportion of sulfate groups, making heparin one of the strongest acids in nature (16).

In parallel with Connaught Laboratories in Toronto, the Swedish company, Vitrium AB, began commercial production of heparin in 1936 (12, 13). Purified heparin became available in the US in 1940 (1).

Clinical Milestones

Up to this time, no reports had been published using Connaught's highly purified heparin to prevent blood clots in patients, but this idea was clearly on the minds of everyone working in the field (9). Leading the clinical investigations in Toronto was Gordon Murray.

Murray had spent 6 years training under master surgeons in London and New York before returning to Toronto General Hospital, where he was appointed to the staff in 1929 (2). His extended years of surgical residency not only honed his outstanding surgical technique but also fostered an interest in research and allowed him to develop as a colorful speaker and writer. He was a courtly and kind man, who handled tissues gently and with the confidence gained through meticulous practice (2).

On April 16, 1937, Murray began the first clinical trials with Connaught's purified heparin at Toronto General Hospital (2, 9, 14). He infused a heparin solution into the brachial artery of a subject for two hours. Blood clotting time significantly increased, and the subject experienced no toxic side effects (5, 12).

Murray's classic papers, which introduced heparin to vascular surgeons, were presented at the American Surgical Association in 1938, the Royal College of Surgeons of England in 1939, and the American College of Surgeons in 1940. By that time, he had published results on more than 400 patients (2).

Murray's work was hailed as "opening up an entirely new field of surgery" (2). He achieved unprecedented success in repairing damaged and occluded arteries, as well as with vein grafts. He also used heparin to prevent and treat venous thrombosis and pulmonary emboli and established the optimum dose and duration of heparin administration (2).

In related work, Murray pioneered hemodialysis for acute renal failure and developed an artificial kidney (2). Many surgeons and physicians came to Toronto specifically to consult with him (9).

In parallel with Murray's work, Clarence Crafoord began clinical studies in Stockholm. Crafoord used Vitrium's heparin, purified by Jorpes's method, and it produced no ill effects in patients (9).

McLean Wants Credit

In New York, Jay McLean conducted sporadic experiments using heparin from Hynson, Westcott & Dunning, which caused some toxicities. But his surgical practice took precedence, and he obtained no important results (1, 9). In 1939, McLean moved to

Columbus, Ohio, and turned from surgery to treating cancer patients with radiation (1, 2).

By 1940, heparin's pharmacological properties were firmly established, and most biomedical researchers credited Howell with the discovery (1, 5). Although Howell had acknowledged McLean's original observations as the impetus for his work, McLean was unhappy at not receiving recognition from other researchers (2, 5).

He began a letter writing campaign to prominent physiologists and enclosed a reprint of his 1916 article for their reference. On the reprint's cover, he stamped a statement, claiming his cuorin and heparphosphatid extracts and Howell's antiprothrombin and heparin were different names for the same substance (2).

For the next seven years, McLean collected a trove of reprints of heparin articles, intending to write a definitive review article or monograph that would support his claim as the discoverer of heparin (1, 5). The manuscript was never completed, and his collection of 1,300 reprints, along with his laboratory notebooks, were, in the end, shipped to Best (1, 9). He told Best, "I would like to see this material in the hands of some enduring group or agency" (2). Best deposited the collection in the library of the University of Toronto's Best Institute, where it remained for many years (2).

From the published reports, it is difficult to sort out the specific origin of heparin (12). Some reviewers have concluded that McLean discovered a phospholipid with anticoagulant activity and not the polysaccharides that Howell's and Best's groups subsequently isolated. Others have suggested that McLean and Howell deserve shared credit: McLean's observations prompted Howell to change the focus and course of his research—something they both agreed upon—and those efforts subsequently led to isolation of pure heparin (12).

Commercializing Heparin

Meanwhile, Best continued his studies, and Connaught Laboratories continued to increase the potency and purity of the heparin it distributed (14). Much of the work to improve production was performed by Edith Taylor and Peter Moloney.

Taylor received her PhD in chemistry from the University of Toronto and joined Connaught Laboratories in 1925 (17). Moloney joined Connaught

Worldwide, 100 tons of commercial grade heparin are now produced annually.

Laboratories in 1919. He earned his PhD in chemistry in 1924 from the University of Toronto for research conducted at Connaught on diphtheria toxoids. He also developed methods for concentrating and purifying insulin (18).



Dr. Edith Taylor

Reprinted with permission from: Samoff Pasteur Canada (Connaught Campus) Archives, Toronto.

In the 1920s, Taylor and Moloney expedited clinical trials of the diphtheria toxoid vaccine (17, 18). Their efforts led to the vaccine's broad use and the virtual elimination of diphtheria in Canada by the early 1930s.

During World War II, Taylor was put in charge of the diphtheria toxoid, tetanus toxoid, and gas gangrene antitoxin production team and made contributions to the production of the pertussis vaccine (17). After the war, Taylor and Moloney turned their attention to optimizing heparin production. They found the best sources of heparin were cow lung and cow or pig intestine—particularly the small intestine (19).

Their method, patented in 1952, increased the yield and lowered the cost of purified heparin (5, 12-14, 19). This cheap production method encouraged competition by other producers, and Connaught stopped selling heparin in the early 1950s.

Pharmaceutical grade heparin consists mainly of repeating disaccharides in polysaccharide chains ranging from 5,000 to 40,000 Daltons (16). It is still commonly extracted from animal tissues, primarily pig intestine, because intestines are plentiful, cheap, and of no other commercial use (14, 16).

Although the commercial processes are proprietary, manufacturers seem to follow the general extraction and purification methods developed by Taylor and Moloney. Some producers use the



Reprinted with permission from: *Sanofi Pasteur Canada (Connaught Campus) Archives, Toronto.*

Dr. Peter Moloney

intestinal mucosa scraped from pig intestine, while others use the whole intestine (“hashed pork guts”) (16). The disaccharide composition of these heparins differs, depending on the subspecies of pig, mast cell content of the intestinal tissue, and the animals’ diet and breeding environment.

Worldwide, 100 tons of commercial grade heparin are now produced annually (16).

Advancing Clinical Practice

As a result of the efforts by Best’s team, purified, nontoxic heparin became widely available. The crystalline sodium salt facilitated hundreds of complex surgical cases in which heparin played an essential and often dramatic, life-saving role (9, 14). Without heparin, surgeon Ronald Baird said, “there would be little vascular surgery, even less [open-heart] surgery, no hemodialysis, and no organ transplantation” (2).

Pulmonary embolism is a common complication of abdominal, thoracic, or urological surgery and can kill patients within 30 minutes (20). Clinical trials in the 1970s showed that low-dose heparin was highly effective in preventing fatal pulmonary embolism and did not produce serious bleeding (21). The standard of care in these cases is now a low dose of heparin 2 hours before surgery and then every 8-10 hours for about a week postoperatively (20).

In the late 1970s and early 1980s, low molecular weight heparins (LMWHs) broadened anticoagulant use. LMWH is a 4,000-5,000 Dalton fragment of the heparin polysaccharide (22). Compared to unfractionated heparin, LMWH has less nonspecific binding to plasma proteins, a longer plasma half-life, better bioavailability, and a more predictable anticoagulant response (22).

Because they can be administered subcutaneously rather than intravenously and without the need for routine lab monitoring, LMWHs progressively replaced

Without heparin, surgeon Ronald Baird said, “there would be little vascular surgery, even less [open-heart] surgery, no hemodialysis, and no organ transplantation”

unfractionated heparin. LMWHs were the preferred drug for prevention and initial treatment of thrombotic disorders until the next-generation oral anticoagulants became available (5, 22).

Toxicity Returns

In January 2008, US public health officials received the first reports of allergic reactions in hemodialysis patients (23). Investigators from the Centers for Disease Control and Prevention quickly excluded contamination in the filters and intravenous tubing used in dialysis and focused on heparin as the common denominator in all of these cases.

In February, Baxter Healthcare, which distributed the tainted product, withdrew all of its heparin batches. Unfortunately, allergic reactions continued to occur, along with the first reports of fatalities (23). Patients undergoing cardiac surgery were also affected. By March, allergic reactions and anaphylactic shock were reported in Europe and Japan, where authorities also recalled the drug. Altogether, several thousand patients were affected and nearly 100 Americans died (16).

Baxter and other distributors had purchased heparin from Scientific Protein Laboratories (SPL) in Changzhou, China (23, 24). The U.S. Food and Drug Administration (FDA) immediately took steps to ensure that all heparin entering the US was stopped and tested for contamination (24).

SPL bought its supplies from two organizations called consolidators, and the consolidators in turn obtained crude heparin from a network of small Chinese workshops. Many of those workshops were unregulated family-owned businesses (24).

Although FDA inspectors found deficiencies in SPL’s facilities and purification procedures, they concluded that the contaminant was not introduced during the manufacturing process (23, 24). Baxter investigators confirmed that the contamination was already present when the heparin supplies were delivered to SPL.

The investigators turned their attention to the consolidators and workshops that extracted and handled the crude material. Unfortunately, Baxter's investigators were denied access to them. FDA officials were hesitant to say how the contamination occurred. But the contaminant made up as much as half of the active ingredient in SPL's final product, suggesting that it was added intentionally (24).

In April 2008, the FDA joined the pharmaceutical industry and a consortium of international laboratories to identify the contaminant. They concluded it was "oversulfated chondroitin sulfate," a semi-synthetic polymer obtained by chemically sulfonating chondroitin sulfate (16, 23).

Chondroitin sulfate is an inexpensive dietary supplement used to treat osteoarthritis. It is extracted from pig cartilage and sells for a fraction of the cost of heparin (16, 24). Chemical conversion to oversulfated chondroitin sulfate is also inexpensive, and some chondroitin sulfate producers in China also sold heparin. Interestingly, a virulent pig virus had swept through China in 2007 substantially reducing the availability of the starting materials needed to make heparin (24).

Chondroitin sulfate is not an anticoagulant, but the oversulfated analog mimics the anticoagulant effect of heparin (16, 23). Unfortunately, oversulfated chondroitin sulfate also activates the kallikrein-kinin pathway to generate bradykinin, which causes an allergic response. It also activates factors that trigger anaphylaxis (16, 23).

To ensure the safety of heparin in the US, the FDA asked manufacturers to test their heparin products with two screening methods that could detect and differentiate contaminants like oversulfated chondroitin sulfate from heparin: capillary electrophoresis and proton nuclear magnetic resonance (25). In June 2008, those test methods were included in the US Pharmacopeia and, going forward, were required for all heparin products intended for the US market (23, 25).

With more pharmaceutical companies sourcing all or part of their manufacturing operations overseas, this incident served as a reminder of the importance of Good Manufacturing Practices. According to international guidelines, to which the FDA and the European Medicines Agency are signatories, pharmaceutical manufacturers are fully responsible for qualifying all of their suppliers through on-site audits, testing, and regular communications.



Heparin sample

Reprinted with permission from: Litchfield - own work. Licensed under CC BY-SA 3.0.

Found and Lost

After Jay McLean's death in 1957, his wife, who was in financial difficulties, began an intensive campaign seeking recognition for his "discovery" of heparin (2, 5). She eventually managed to get Upjohn to award Jay McLean a \$6000 cash prize, payable to her, and a bronze plaque recognizing his discovery at Johns Hopkins (2).

Medical school officials at Johns Hopkins held extensive discussions regarding an appropriate size and wording of the plaque. The medical school dean said, "The contribution made by Dr. McLean to the discovery of heparin has been somewhat of a controversial issue...and we at Hopkins have not been altogether happy about some of the implications" (2).

The final engraved plaque was unveiled at Johns Hopkins on May 3, 1963 commemorating Jay McLean "in recognition of his major contribution to the discovery of heparin in 1916, as a second-year medical student in collaboration with Professor William H. Howell" (2, 5, 13).

In Toronto, university officials made changes after the death of Charles Best in 1978. The Best Institute merged with the adjoining Banting Institute to form the Banting and Best Diabetes Centre and was relocated to new facilities. The original Institute buildings then housed the Banting and Best Department of Medical Research until 2005. Now called the Donnelly Centre, those buildings currently accommodate entrepreneurial startups and other commercialization partner tenants. In the midst of these changes, McLean's collection of notebooks and reprints was lost (2).

References

1. Ricci R and Agus G (2013) One hundred years since the discovery of heparin, not so long ago. The story of a loser; available from: <https://www.pagepressjournals.org/index.php/vl/article/view/AncestCorner.2013.1/1355>.
2. Baird RJ (1990) "Give us the tools..." The story of heparin—as told by sketches from the lives of William Howell, Jay McLean, Charles Best, and Gordon Murray. *J Vascul Surg* **11(1)**: 4-18.
3. McLean J (1959) The discovery of heparin. *Circulation* **19(1)**: 75-78.
1. Erlanger J (1951) William Henry Howell 1860-1945. *Biographical Memoirs* **26**: 153-180, National Academy of Sciences, Washington, DC.; available from: <http://www.nasonline.org/publications/biographical-memoirs/memoir-pdfs/howell-william.pdf>.
2. Wardrop D and Keeling D (2008) The story of the discovery of heparin and warfarin. *Br J Haematol* **141(6)**: 757-763.
3. McLean J (1916) The thromboplastic action of cephalin. *Am J Physiol* **41(2)**: 250-257.
4. Erlandsen A (1907) Untersuchungen über die lecithinartigen Substanzen des Myocardiums und der quergestreiften Muskeln. *Zeitschr Physiol Chem* **51**: 71-155.
5. Baskoff A (1908) Über das Jecorin und andere lecithinartige Produkte der Pferdeleber. *Zeitschr Physiol Chem* **57**: 395-460.
6. Best CH (1959) Preparation of heparin and its use in the first clinical cases. *Circulation* **19(1)**: 79-86.
7. Howell WH and Holt E (1918) Two new factors in blood coagulation—heparin and pro-antithrombin. *Am J Physiol* **47(3)**: 328-341.
8. Howell WH (1925) The purification of heparin and its presence in blood. *Am J Physiol* **71(3)**: 553-562.
1. History of heparin. *Heparin Science*; available from: <https://www.heparinscience.com>.
1. Lim GB (December 14, 2017) Discovery and purification of heparin. *Nat Rev Cardiol*; DOI: <https://www.nature.com/articles/nrcardio.2017.171>.
1. Ruddy CJ (1996) Miracle blood lubricant: Connaught and the story of heparin, 1928-1937. *Connctact* **9(4)**; available from: <http://www.healthheritageresearch.com/Heparin-Connctact9608.html>.
1. Insulin Library. Biography of Charles Herbert Best (1899-1978). University of Toronto; available from: <https://insulin.library.utoronto.ca/about/best>.
2. Liu H, Zhang Z, and Linhardt RJ (2009) Lessons learned from the contamination of heparin. *Nat Prod Rep* **26(3)**: 313-321.
1. Profiles (2019) *Museum of Healthcare*; available from: <http://www.museumofhealthcare.ca/explore/exhibits/vaccinations/profiles.html>.
1. Synan EA (May 27, 2011) The Life of Dr. Peter Moloney: Biography by Synan; available at: <http://www.drpetermoloney.com/biography/biography-by-synan>.
2. Taylor EM and Moloney PJ (March 4, 1952) Methods of producing heparin. US Patent 2,587,924.
1. Lim GB (December 14, 2017) Low-dose heparin for VTE—prevention is better than cure. *Nat Rev Cardiol*; available from: <https://www.nature.com/articles/nrcardio.2017.174>.
2. Kakkar VV (1978) The current status of low-dose heparin in the prophylaxis of thrombophlebitis and pulmonary embolism. *World J Surg* **2(1)**: 3-18.
1. Fernández-Ruiz I (December 14, 2017) A breakthrough for out-of-hospital treatment of thrombosis. *Nat Rev Cardiol*; available from: <https://www.nature.com/articles/nrcardio.2017.177>.
1. The heparin contamination crisis. *Heparin Science*; available at https://www.heparinscience.com/contamination_crisis.html.
1. Bogdanich W (March 20, 2008) Heparin find may point to Chinese counterfeiting. *New York Times*; available from: <https://www.nytimes.com/2008/03/20/health/20heparin.html>.
1. US Food & Drug Administration (2018) Postmarket drug safety information for patients and providers; available from: <https://www.fda.gov/Drugs/DrugSafety/PostmarketDrugSafetyInformationforPatientsandProviders/ucm112597.htm>.



The Pharmacologist,
Volume 61,
Number 3,
September 2019



Warfarin: An Auspicious Student Project

Rebecca J. Anderson, PhD

On a frigid Saturday morning in February 1933, Ed Carlson hoisted a dead cow into his pickup truck—the latest in a series of cattle losses on his farm that winter. In December, two of his young heifers had died. In January, his favorite old cow had developed a massive hematoma on the thigh. When it was lanced, the bleeding proved fatal. Then, on a Friday in February, two more cows died, and Carlson’s bull was oozing blood from its nose (1, 2).

To the local veterinarian in Deer Park, Wisconsin, the problem was all too familiar. He told Carlson there was a hemorrhagic toxin in his hay. Carlson doubted that explanation. He had been feeding the same sweet clover hay to his cattle for years with no ill effects. He decided to get another opinion—from state experts (1-3).

So, on that Saturday in February, Carlson drove 190 miles through a blizzard to the Agricultural Experiment Station in the state capital. Unfortunately, when he arrived, the State Veterinarian’s office was closed (1, 2).

But in the Biochemistry Building of the University of Wisconsin, Karl Paul Link and his student assistant,

Eugen Wilhelm Schoeffel, were still at work. Carlson hauled in the dead cow, along with a milk can of unclotted blood and about 100 pounds of hay (1-3). Link listened intently as Carlson related his sad saga. Although Link was not a veterinarian, he recognized the symptoms. They fit “perfectly with the classical sweet clover poisoning picture” (2).

Sweet Clover Turns Sour

Link first heard about sweet clover disease just two months before Carlson’s arrival. Ross Gortner, the chairman of biochemistry at the University of Minnesota, had invited Link for an interview (2). Gortner gave him publications by the original researchers of sweet clover disease, which was also a problem in Minnesota. He invited Link to join the lab’s efforts to identify the substance in the hay that was causing the bleeding.

This hemorrhagic disease was first characterized in the 1920s by two veterinarians, Lee M. Roderick in North Dakota and Frank W. Schofield in Alberta,

Canada (1, 4, 5). They systematically excluded a pathogen or nutritional deficiency as the cause (1, 2). The bleeding was sporadic, but they found that it correlated with years when the summer and autumn were unusually wet. Hay that was stored while still damp turned moldy.

Sweet clover disease appeared within 15 days of ingestion of the spoiled hay and killed the animal within 30-50 days (1-3). But Schofield and Roderick found that the symptoms could be reversed by removing spoiled hay from the animals' diet and transfusing sick cows with fresh blood from healthy animals (1-3, 5).

Link gave Carlson the same advice. Sadly, though, he and Schoeffel both knew the poor farmer could not afford to discard his only stacks of hay nor pay for transfusions. The economic hardship of the Great Depression forced farmers to feed moldy hay to their cattle (1, 3, 5). After a disheartened Carlson left for his long journey back to Deer Park, Schoeffel could contain his rage no longer.

Schoeffel came to the US in 1926 from southern Germany with a diploma in agricultural chemistry (1, 2). He joined Link's laboratory as an assistant in 1929. Energetic and loyal, he frequently quoted Goethe and Shakespeare and spoke with an earthy, guttural Swabian-German accent (2).

Schoeffel paced back and forth, shouting 'Get some good hay.' Ach!! Gott, how can you do dat ven you haf no money?' (2).

He dipped his hands repeatedly into the milk can, muttering, "Dere's no clot in dat blook!" (2). That same afternoon, at Schoeffel's urging, they began searching for the cause of sweet clover disease.

An Analytical Showman

Of all the researchers investigating sweet clover disease, Karl Link was uniquely positioned to succeed. A generous, kind, and thoughtful person, Link was also a prolific and analytical notetaker. The heading of even his personal letters, for example, included specific meteorological data: "Temp. 30F., B.P. 29.93", overcast-snow is predicted. IX/26/67 at 5:00 A.M. C.S.T." (6).

Link obtained his PhD in agricultural chemistry from the University of Wisconsin in 1925, studying the carbohydrates in corn seedlings. Postdoctoral work in Europe introduced him to microchemical analysis, which he soon mastered. Returning to the University of Wisconsin as an assistant professor in



Karl Paul Link

agricultural chemistry, Link continued researching the carbohydrates in plants and set up a state-of-the-art microchemical analysis unit (6).

Link dressed to attract attention, wearing large bow ties, flannel shirts, and shorts. He taught with a flair, holding the students' attention like a showman. They loved him, and he always had their back (6).

Link had already established himself as one of the outstanding carbohydrate chemists of his day when his attention was drawn to sweet clover hay. He had decided to stay in Madison, rather than accept the Minnesota position, and his first sweet clover research had nothing to do with hemorrhagic disease. In January 1933, R.A. Brink and W.K. Smith asked for his assistance with their sweet clover husbandry studies (2).

Coumarin gives new mown hay its characteristic scent, but it tastes bitter. Taste tests in cattle and rabbits showed that they preferred sweet clover plants (*Melilotus alba* and *M. officinalis*) that have low coumarin content (1-5, 7). Brink and Smith, in the university's genetics department, wanted to develop a strain of sweet clover that was low in, or free from, coumarin and that would thrive in Wisconsin's climate (1, 2).



In the public domain

M. officinalis

Catching the Big Fish

Link and his genetics colleagues expanded their studies of sweet clover after Ed Carlson's visit. To isolate the hemorrhagic agent, they needed to measure the extent of blood clotting in each fraction they extracted from the spoiled hay. Unfortunately, all of the published assay methods gave unreliable results.

Link had no previous experience with blood coagulation, but this was a good student project. Starting from scratch, Schoeffel and another student, Willard L. Roberts, began developing a quantitative bioassay, taking full advantage of Link's microanalysis facilities (2).

In May 1937, when Schoeffel moved to a lab of the American Medical Association in Chicago, the assay development work was transferred to another student, Harold A. Campbell (6). Because of wide variations in clotting of blood from individual rabbits, Campbell (with the assistance of geneticist Smith) bred and reared a colony of susceptible rabbits specifically for the assay.

Using blood from those rabbits, Campbell succeeded in developing a reliable bioassay in 1938 (2).

In parallel, Link, Smith, Roberts, and especially Campbell labored to extract, separate, and isolate the hemorrhagic substance from spoiled sweet clover hay (2, 7). After many dead ends, Campbell finally succeeded. At dawn on June 28, 1939, after working all night, he peered through his microscope and saw the crystalline substance. Two hours later, he had collected about 6.0 mg of it (2, 6). He worked nonstop for two more days to collect data on its anticoagulant effect.

Campbell was a no-nonsense worker, not inclined to show his emotions, but when he presented Link with a vial of the crystalline substance and his bioassay results, he was "as happy as a boy who had just caught his first big fish" (2). They sent a telegram to Schoeffel, who, employing his unique wordsmithing, immediately replied that he had "complete confidence in Nature, Fate, and [you]" (2).

Campbell isolated the compound three more times before receiving his PhD in October 1939. Then, another graduate student, Mark A. Stahmann, assumed leadership of the project. Stahmann had been working in Link's lab since 1936, studying plant disease resistance (2, 6). Although he had almost completed his thesis work, he turned his attention, at Link's request, to large-scale extraction of the substance Campbell had isolated (2).

More Student Projects

Stahmann acquired a number of oak barrels and drew on the large supply of spoiled sweet clover hay



Mark A. Stahmann and Karl Paul Link

Reprinted with permission from UW-Madison Archives, S00094

that Willard Roberts had gathered and stored in the campus horse barn (2, 6). Knowing the compound's chemical properties, he was able to develop a shorter and more efficient extraction procedure (7).

After 4 months' effort, Stahmann had extracted about 1.8 grams of the crystalline compound (2, 6, 7). This was enough material to dose rabbits and confirm that the substance's anticoagulant effect was identical to that obtained by Campbell when his rabbits were fed spoiled hay samples (7).

They were also able to elucidate the compound's chemical structure. Charles F. Huebner, a sensitive, brilliant, and deft student researcher with a lively imagination, conducted most of that work (6). In short order, he arrived at the correct structure: 3,3'-methylenebis (4-hydroxycoumarin). It was an oxidized form of coumarin, in which two hydroxycoumarin molecules were fused together.

Knowing the chemical structure, Link thought it plausible that both of the undesirable properties of sweet clover (the bitterness of green hay and the tendency to cause hemorrhage when improperly cured) derived from a common source: coumarin (2, 7). So, Link called this "double-coumarin alcohol" dicumarol.

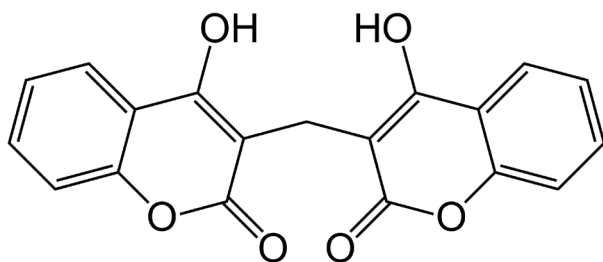

In the public domain

Chemical structure of dicumarol

In January 1940, Huebner began efforts to synthesize dicumarol, using simple starting materials including acetylsalicylic acid (6). He succeeded on April 1, 1940 (1, 2). Huebner's synthetic compound had chemical and physical properties identical to the natural product that Campbell and Stahmann had extracted from spoiled sweet clover (2, 6).

In reviewing the literature, they found that two German chemists, Anschutz and Fresenius, had synthesized the compound in 1903, but those chemists did not realize that it had anticoagulant properties (6). Campbell was the first person to extract dicumarol from a source in nature.

On April 5, 1940, Ralph Overman, another student in Link's lab, confirmed that the synthetic and naturally extracted compounds were biologically equal when

tested in the rabbit bioassay (2, 6). Eventually, investigators determined that molds such as *Penicillium nigricans* and *Penicillium jensi* convert the coumarin in damp sweet clover hay to dicumarol (3, 8).

Stahmann and Link found that the molds convert only a very small fraction of the total coumarin in sweet clover to dicumarol. They concluded that it was impractical to control the hemorrhagic action by developing sweet clover strains with low coumarin content (7). The most efficient way to manage sweet clover disease remained discarding the spoiled hay and transfusing affected animals with fresh blood.

Roderick and Schofield had reported that the hemorrhagic syndrome does not cause permanent injury. Eating spoiled hay, even for long periods (short of death), caused no permanent functional change, no morphologic change, and in the liver, no detectable pathologic changes (2, 3).

Similarly, Stahmann and Link found that a single massive dose of dicumarol—although, predictably, affecting blood clotting—did not produce gross signs of injury. Even subjecting rabbits repeatedly to dicumarol more than 100 times (with a rest period in between) did not cause permanent injury, immunity, or increased susceptibility to dicumarol—despite causing a large reduction in clotting activity after each dose (7).

To cause fatal hemorrhages, they concluded, dicumarol needed to be administered repeatedly and aggressively. "The spread between the detectable and lethal dose, together with the relative ease with which it may be synthesized and administered," they said, gave dicumarol favorable properties that might be useful to both physiologists and clinicians (7).

On April 9, 1940, Link proudly reported to the dean of the College of Agriculture that all of this work to isolate and synthesize dicumarol had been conducted by graduate students in training for their PhD degrees. He also said that they were preparing analogs that were more potent and worked more rapidly than dicumarol, as well as exploring whether those analogs would be useful clinically (6).

The WARF Path

Into the 1930s, most universities (as nonprofit institutions) concentrated on basic research and saw ethical difficulties with controlling intellectual property and earning profits from their scientific discoveries. Few managed their own patents (9, 10). The University of Wisconsin was a rare exception.

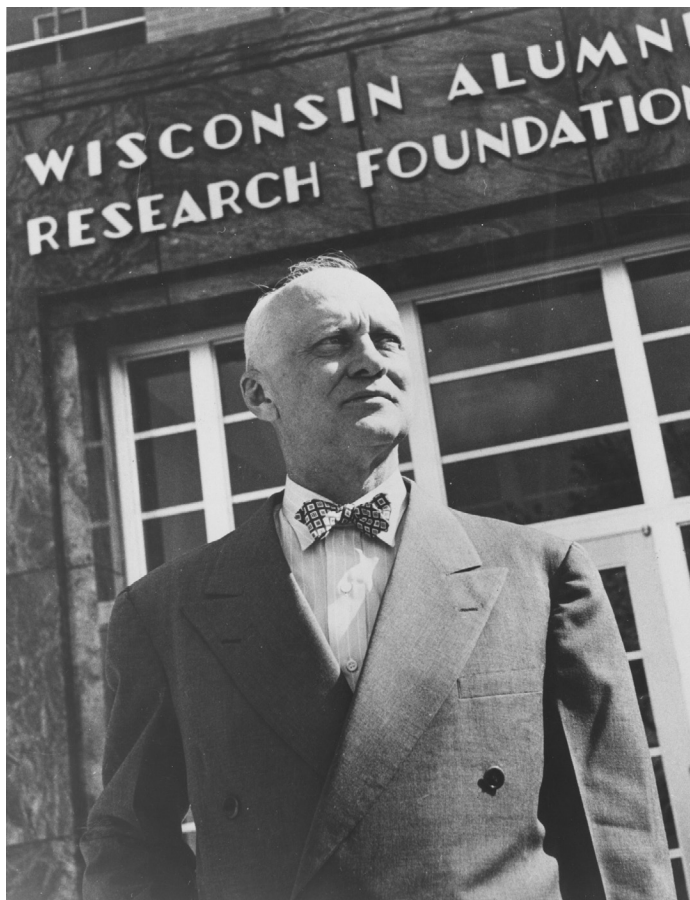

Reprinted with permission courtesy of the Wisconsin Alumni Research Foundation

Harry Steenbock

In the early 1920s, Harry Steenbock, a professor of biochemistry, discovered that certain dietary fats could be fortified with vitamin D when exposed to ultraviolet light (9-11). Vitamin D was a relatively unknown substance at the time, but the financial potential of vitamin D as a dietary supplement was huge (11). Unfortunately, the president of the University of Wisconsin was reluctant to support Steenbock's efforts to apply for patents (10). He was concerned that the potential benefits would not justify the expense. Also, University-sponsored patenting was controversial, and unorthodox, especially among Progressives in the state government (10).

In a creative move, Steenbock, along with the deans of the College of Agriculture and the Graduate School, proposed—and the university's regents endorsed—creation of an independent, nonprofit corporation run by alumni trustees. This corporation, the Wisconsin Alumni Research Foundation (WARF), was the first university-affiliated patenting office (9, 10). It managed the university researchers' patents and invested the resulting revenue in faculty research projects (9, 11).

WARF's first initiative was to patent and commercialize Steenbock's vitamin D discoveries, which contributed to the virtual elimination of rickets (caused by vitamin D deficiency). Vitamin D sales also generated millions of dollars for university research (11, 12).

Subsequently, WARF managed the patents of other university researchers (11). Among them were Link and Stahmann, who, with the assistance of WARF, filed a patent for dicumarol in 1941 (3, 5, 12). The co-inventors assigned their patent rights to WARF, and in exchange they received 15% of the net income (10).

Therapeutic Limitations

From 1940-1942, Link's group characterized the pharmacology of dicumarol. The onset of anticoagulant action lagged 12-24 hours after dicumarol administration, but the effect accumulated with repeated dosing (2). Efficacy varied, based on species (rabbit, rat, guinea pig, mouse vs. dog blood), age, nutritional status, interactions with other drugs, hepatic and renal function, and pregnancy (2, 7).

Dicumarol is structurally similar to vitamin K and acts as a competitive inhibitor, preventing fibrinogen from forming clots (1, 5, 8, 13). Link found that vitamin K counteracted the anticoagulant action of dicumarol so effectively that he was certain it could serve as an antidote in cases of excessive bleeding (2).

Studies in patients at the Mayo Clinic and Wisconsin General Hospital in the early 1940s confirmed that dicumarol delayed coagulation and prolonged prothrombin time (2, 6). Vitamin K counteracted the anticoagulant effect, and unlike heparin, dicumarol was effective when given orally. These observations facilitated dicumarol's acceptance in clinical practice (6).

But because of the long lag time before onset of the therapeutic effect and the long excretion time, the drug was less than ideal (1, 2, 5). Clinicians would have preferred an oral anticoagulant with better pharmacokinetics (2).

A Perfect Poison

In the two years after Huebner first synthesized dicumarol, Link's students made over 150 analogs (1, 2). Some exhibited a slower but more sustained anticoagulant action, while others had a shorter duration than dicumarol. Some were more potent, and their solubility varied (1, 6).

As World War II proceeded, work in Link's laboratory slowed to a crawl because many of his students were serving in the armed forces (2). In September 1945, still awaiting their discharge from service, Link took a rare

Of 1,386 of the Nation's County Agricultural Agents . . .

98.4%* report "Complete or Satisfactory" control with warfarin

- ✓ 34.2% "COMPLETE KILL"
- ✓ 64.2% "SATISFACTORY CONTROL"
- ✓ 1.6% "UNSATISFACTORY RESULTS"



To test the effectiveness of warfarin on a nationwide basis, county agricultural agents in all of the 48 states were asked to report on local results obtained on a representative number of good, average, and poor farms. The 1,386 county agent reports received represent thousands of individual baiting trials. These reports conclusively show:

1. That warfarin can be used effectively by the untrained person, merely by following the label instructions. In the survey, all trials were made by untrained persons without the benefit of special instructions.
2. That warfarin can be used effectively in every state in the Union under all different geographical conditions.
3. That warfarin can be used effectively under all climatic conditions.
4. That warfarin can be used effectively against all forms of rats and mice found in the United States.

WARFARIN PRODUCES RESULTS!
Ask your county agricultural agent, or your local health officer

*In a follow-up survey, 18 out of 19 county agents who originally reported "unsatisfactory results" have, after additional experience with warfarin, reported highly satisfactory control.

warfarin PROVIDES CONTINUOUS CONTROL



Ordinary "quick-kill" baits (black line) create "bait shyness" and allow a rebuilding of the population. Slow-acting warfarin baits (green line), when properly used, reduce the rat population to the lowest possible level, then keep it there.

warfarin rat and mouse killers
ARE RECOMMENDED FOR:

FARMS	HOMES
FOOD STORES	RESTAURANTS
SHIPS	WAREHOUSES
BAKERIES	MILLS AND ELEVATORS
FEED STORES	CHEESE FACTORIES
DAIRIES	MARKETS
FUR FARMS	HATCHERIES
POULTRY FARMS	HOSPITALS
PACKING PLANTS	STOCKYARDS
SUGAR CANE PLANTATIONS	APARTMENTS
MANUFACTURING PLANTS	ZOOS
RESORTS	ALLEYS
PARKS	DUMPS

... AND ALL OTHER PLACES
SUBJECT TO RAT OR MOUSE INFESTATION.



The New, Proven Way to
KILL RATS
and mice — with
RODENTICIDES
containing newly-discovered
warfarin*

* Warfarin is a substance discovered at the University of Wisconsin and developed by the Wisconsin Alumni Research Foundation.

© 1951, WARF
W6REV. Printed in U. S. A.

Reprinted with permission courtesy of the Wisconsin Alumni Research Foundation

1951 warfarin advertisement

break from the laboratory. While on a canoe trip with his family, he was caught in a rainstorm. Soaked and chilled, he suffered a recurrence of tuberculosis, which he had first contracted during his postdoctoral training in Europe (2).

Link spent two months in Wisconsin General Hospital and then six months recuperating at the Lake View Sanatorium (6). Stahmann, who had taken a position at Rockefeller Institute in 1942 after receiving his PhD, returned to Wisconsin to supervise Link's lab during his absence.

To keep his mind occupied while his body recovered, Link reviewed the accumulated data on the dicumarol analogs. He was looking for compounds with favorable chemical properties: a high degree of purity, absence of taste and odor, low cost of goods, and the ability to be easily converted to stable water-soluble salts (2). He also read a book on the control of rodents from ancient to modern times.

When Lester D. Scheel returned from military service in the spring of 1946, Link asked him to collect more data on the anticoagulant activity of analogs numbered 40-65. Those compounds had been made by Miyoshi Ikawa in 1942-1943 (2). Scheel reported that compound no. 42 was much more potent than dicumarol in rat and dog blood,

and it produced a more uniform anticoagulant response (2, 6). It had been so potent in the original rabbit bioassay that Link—concerned about toxicity—had made no move to patent it (6).

Despite Link's reservations, Mark Stahmann thought no. 42 had potential. In February 1945, he contacted WARF to initiate a patent application (6). WARF's attorney filed the patent on compound no. 42 in April

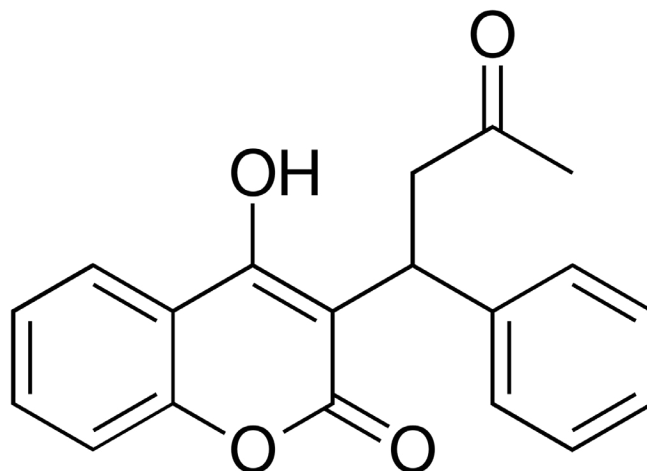

Chemical structure of warfarin

In the public domain

1945, with Link, Stahmann, and Ikawa as co-inventors (6, 14). Later, they also patented the sodium salt, which was more water-soluble.

When Link returned to the lab, he proposed using no. 42 as a rodenticide (2). Field tests confirmed that the compound was effective (15). Unlike other rat poisons, no. 42 was toxic only after accumulation of multiple small doses over 3-6 days (2, 8, 15). The rodents ate the bait until hemorrhage set in—just like the cattle that ate spoiled sweet clover hay—and died without awareness that they were sick. They neither refused nor avoided the bait, making it an ideal poison (2, 15).

Link coined the name for no. 42. By combining WARF's initials with "arin" from coumarin, he came up with "warfarin" (2). He consulted WARF attorneys and scientists, who assisted with development of warfarin as a commercial rodenticide. The concentrated product contained 0.5% warfarin in cornstarch. Customers prepared bait by cutting the warfarin-concentrate with a grain (usually cornmeal) to a final ratio of 1:4,000 (15).



In the public domain

A d-CON can

One popular warfarin product, d-CON, also contained a vegetable oil that rodents were fond of (15). Through WARF's intensive promotional efforts, warfarin, in short order, revolutionized rodent control (2, 10).

From Poison to Patients

Link also re-examined the accumulated data on the dicumarol analogs from a physician's perspective. He hoped to find one that retained the virtues of dicumarol but overcame its clinical limitations.

Warfarin stood out. Like dicumarol, its anticoagulant effect could be reversed with vitamin K (2, 3, 5, 6). But compared to dicumarol, warfarin had greater water solubility, higher oral bioavailability, and a faster onset of action (2, 5).

Link knew that anticoagulant potency varied widely between species, and from what he saw in the warfarin data, he concluded that the toxicity in rats was not a reliable indicator of how patients would respond. In late 1950, he suggested to Ovid Meyer at the University of Wisconsin and Shepard Shapiro at New York University that they should try the water-soluble sodium salt of warfarin in their patients. But convincing clinicians to prescribe a rat poison "was a bit more than they could accept with real enthusiasm" (2).

Then, on April 5, 1951, Link received support from an unexpected and unlikely source. Captain Julian Love in the US Naval Medical Corps called and described a case of attempted suicide using warfarin (2).

On March 26, 1951, a 22-year-old man (depressed at being drafted into the US Army and destined for Korea) ate a small portion of concentrated d-CON. It tasted somewhat sweet, like marshmallow, and caused no unpleasant sensations (15). Because that single dose failed to produce the intended results, he continued taking equal daily amounts, consuming an entire 4-ounce canister of d-CON over 6 days—a total of 567 mg of warfarin (100 times the therapeutic dose) (15).

He finally began experiencing symptoms: abdominal pain, nose bleeds, and an episode of vomiting. Frustrated and increasingly uncomfortable, he went to the Naval Hospital in Philadelphia, where he was admitted on April 4, 1951 (15).

The marked decrease in blood clotting, along with the patient's confession that he had eaten d-CON, established a diagnosis of warfarin poisoning. Physicians in the Naval Medical Corps administered daily transfusions of fresh whole blood and intravenous vitamin K. After 1 week of treatment, the

patient's prothrombin time returned to normal, and he made a complete recovery (15).

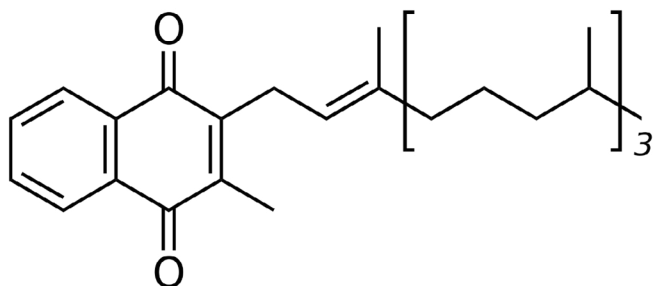

In the public domain

Chemical structure of vitamin K1

This case study, published in 1952, was the first evidence of warfarin's wide safety margin in humans. It also confirmed the effectiveness of reversing warfarin overdose with blood transfusions and vitamin K. The Naval officers concluded that "taking the drug for suicidal purposes would require marked perseverance and a continued desire..." (15).

This incident made it easier to convince clinicians that warfarin was safe. Meyer and Shapiro conducted meticulous studies and confirmed that warfarin was superior to dicumarol and the other anticoagulants they had tried (2, 16). In addition to its greater potency and good bioavailability by any route, warfarin acted faster than dicumarol. They also confirmed that vitamin K readily controlled bleeding.

Link convinced his friend, S. M. Gordon, at Endo Laboratories in Richmond Hill, NY, to produce the water-soluble salt of warfarin for clinical use. Endo Laboratories marketed it under the tradename, Coumadin Sodium[®], which was approved for human use by the FDA in 1954 (2, 4, 5, 12).

A Presidential Boost

In 1955, another event raised the standing of warfarin even further (6). In August, President Dwight Eisenhower arrived in Denver for a working vacation at the home of his in-laws (17). After a round of golf at the Cherry Hills Golf Club on Friday, September 23, he complained of indigestion and retired at 10 pm (17, 18). He awoke at 2:30 am with a dull pain in his chest and took milk of magnesia, his usual remedy for indigestion (18). As a precaution, Mrs. Eisenhower contacted his personal physician, Major General Howard Snyder, who arrived at the Doud home at 3:00 am.

Snyder gave Eisenhower amyl nitrite, papaverine, morphine (for his pain and possible angina), and heparin (for possible thrombosis) (18). While

Eisenhower slept that morning, Snyder summoned cardiologists from nearby Fitzsimons Army Hospital. They brought an electrocardiograph, and the EKG indicated a left anterior infarction.

Eisenhower was informed that he had suffered a heart attack, and he was transported to Fitzsimons in a Secret Service car. After admission to a suite of rooms on the hospital's eighth floor, Eisenhower was placed in an oxygen tent and continued taking heparin (17, 18).

Eisenhower had confidence in the army specialists at Fitzsimons and Walter Reed Army Hospital, whom Snyder consulted. But the president's advisors thought the public would be reassured and perhaps have more confidence, "however unwarranted," in a civilian heart specialist (18). So, Snyder contacted Paul Dudley White, chief of cardiology at Massachusetts General Hospital and famous for his collaborations to describe the Wolff-Parkinson-White syndrome. White arrived in Denver by Air Force plane on Sunday morning (18).

Aware of criticism surrounding coverups of previous presidents' illnesses, Eisenhower instructed his staff to tell the public everything. At a press conference on Monday, White detailed the president's condition, down to his bowel movements (18). A few days later, Eisenhower's press secretary issued an update, announcing that Coumadin (warfarin) had replaced heparin, and "the present prothrombin level has been well maintained" (2).

"the most important man in the world today was being anticoagulated via warfarin sodium"

In Madison, after reading the press release in the newspaper, Link was pleased that "the most important man in the world today was being anticoagulated via warfarin sodium" (2). Eisenhower continued taking warfarin for years (18).

Clinical Success

By the late 1950s, considerable anecdotal evidence had accumulated that heparin and/or warfarin were effective in reducing venous thrombosis and pulmonary embolism, but complicating factors clouded interpretation of this evidence (19, 20). Physicians identified pulmonary embolism through a combination of signs and symptoms, but they rarely could make a

definitive diagnosis before death (19). Also, despite some strong advocates, many physicians and surgeons were still reluctant to use anticoagulants routinely because of the risk of hemorrhage.

In 1957, British investigators began enrolling patients in the first randomized, placebo-controlled clinical trial (19). Treatment with heparin and the warfarin analog, acenocoumarol, completely prevented deaths and non-fatal recurrences from pulmonary embolism, whereas 5 of 19 patients in the placebo group died and 5 others had non-fatal recurrences (19, 20). With such a dramatic effect, the investigators changed the trial protocol, asserting that it was unethical to withhold treatment. All of the next 54 patients in the trial received the heparin-acenocoumarol combo, and none of them died from pulmonary embolism (19, 20).

This landmark study, which was published in 1960, provided the first conclusive evidence that anticoagulant treatment was effective in thromboembolic patients. It also paved the way for additional randomized clinical trials (20). Among other things, those clinical trials showed that warfarin can reduce the chance of stroke by half (8). By the end of the 1970s, long-term treatment with warfarin was the standard of care for preventing recurrence of venous thromboembolism (21).

Warfarin became the most widely used anticoagulant in the world (3, 4). It is viewed by many as the best medication to prevent and treat deep-vein thrombosis and pulmonary embolism, and to prevent stroke in patients who have atrial fibrillation, valvular heart disease, or a prosthetic heart valve (3, 8). As the size of the elderly population increased, warfarin use also increased, from 21 million outpatient prescriptions in 1998 to nearly 35 million in 2010 (22).

Getting the Dose Right

From the beginning, warfarin dosing was a challenge because of large variations in individual responses (23). A 40-fold inter-patient variation in dose has been recorded—among the highest individual variation on record for any drug (1). Contributing factors include dietary vitamin K, interactions with other drugs, and patient compliance.

Because this variation leads to a high incidence of bleeding complications in sensitive patients, regular lab monitoring was needed (1). Prothrombin time, first developed in 1935, was the earliest blood test for oral

anticoagulant activity (23). But its drawbacks included inter-lab variability and inconsistent methods of data reporting (i.e., time, ratio, or percent activity). And, the commercial reagents supplied for the assay varied in their sensitivity (1, 23).

In 1977, recognizing the need for a standardized measure of prothrombin time, the Expert Committee on Biological Standardization of WHO proposed a scheme for calibrating thromboplastin reagents. In 1983, with further improvements in the methods, the WHO Expert Committee approved a revised scheme, giving rise to the International Normalized Ratio (INR). All manufacturers were required to provide an “international sensitivity index” for their thromboplastin reagents, which is needed to calculate the INR (3, 23).

INR expresses the prothrombin time measured with any reagent as a normalized ratio (3). The average person’s INR is around 1.00. The American College of Chest Physicians recommends an INR range of 2.0 to 3.0 for patients at risk of recurrent venous

“It is a shining example of student research productivity”

thromboembolism or patients with atrial fibrillation and a medium-to-high risk of stroke (1, 23). For a minority of conditions with a high thrombotic risk (such as mechanical heart valves), the INR is maintained between 2.5 and 3.5 (1, 23).

By 1995, most labs in the US were reporting INR values, and it is still used to monitor patients taking warfarin (3, 23).

Dogged Dosing Difficulties

Still, optimal dosing remains a challenge. Even at the best clinical centers, doctors find calibrating the clinical dose based on INR tedious and difficult (1). A recent survey showed that patients taking warfarin were within their INR target range only 50% of the time (1, 4).

The main risk associated with warfarin continues to be bleeding complications, which are responsible for about 30,000 emergency room visits a year in the US (4, 22). Except for insulin, warfarin is the prescription drug most frequently implicated in emergency room visits (24).

In addition to long-established factors (dietary vitamin K, age, gender, overall health, and concomitant medications), approximately one-third of patients receiving warfarin have genetic variants of CYP2C9 and VKORC1 and are at a higher risk of bleeding (4, 22, 24). Those genetic variants affect the metabolism and inhibition of warfarin and account for 55% of the variation in warfarin's effects (4).

In 2007, the FDA approved the first of several diagnostic tests that detect both of these genetic variants in patients (24, 25). A recently published study reported that genotype-guided dosing significantly reduced the risk of adverse events from warfarin, compared with clinically-guided dosing alone (26).

Link's Legacy

Even with genetic testing, the use of warfarin is complicated by the need for frequent INR monitoring and dose adjustments, and patients must still be mindful of potential drug interactions and foods containing vitamin K (27). To address these drawbacks, a new class of anticoagulant drugs was developed.

Four next-generation drugs have been approved for managing various thromboembolic disorders: dabigatran (Pradaxa®), rivaroxaban (Xarelto®), apixaban (Eliquis®), and edoxaban (Savatsa®). They are at least as effective as warfarin and do not require routine prothrombin monitoring, dietary restrictions, or frequent dose adjustments (27). Their convenience has resulted in a reduction of warfarin prescriptions to about 19 million in 2016.

Despite their advantages, though, the newer anticoagulants are much more expensive than warfarin, which remains the most frequently prescribed oral anticoagulant (3, 4, 23).

Karl Link was elected to the National Academy of Sciences in 1946. He also received Lasker Awards in 1955 and 1960 for basic research and clinical research, respectively (6). But he always credited his graduate students for their key role in the discovery of dicumarol and the development of warfarin. It is a shining example of student research productivity. "They never cease to wonder, they kept on trying, and they were on a project directed toward doing mankind some good" (2). Indeed, many millions of patients have benefitted. And WARF's anticoagulant patents generated \$16.8 million (\$150 million in today's currency) for the university (10).

References

- Duxbury BM and Poller L (2001) The oral anticoagulant saga: past, present, and future. *Clin Appl Thromb Hemost* **7(4)**: 269-275.
- Link KP (1959) The discovery of dicumarol and its sequels. *Circulation* **19(1)**: 97-107.
- Wardrop D and Keeling D (2008) The story of the discovery of heparin and warfarin. *Br J Haematol* **141(6)**: 757-763.
- Pirmohamed M (2006) Warfarin: almost 60 years old and still causing problems. *Br J Clin Pharmacol* **62(5)**:509-511.
- Lim GB (December 14, 2017) Warfarin: from rat poison to clinical use. *Nat Rev Cardiol*; DOI: <https://doi.org/10.1038/nrcardio.2017.172>.
- Burriss RH (1994) Karl Paul Link, January 31, 1901-November 21, 1978. *Biogr Mem Natl Acad Sci* **65**: 176-195.
- Stahmann MA, Huebner CF, and Link KP (1941) Studies on the hemorrhagic sweet clover disease. V. Identification and synthesis of the hemorrhagic agent. *J Biol Chem* **138**: 513-527.
- Guillory J (2002) The story of Coumadin. *The Examiner* **7(4)**.
- The discovery that inspired a foundation. The History of WARF (2018); available from: <https://www.warf.org/about-us/history/history-of-warf.cmsx>.
- Walters KA (2019) Before the foundation: Harry Steenbock and the patenting of university science, 1886-1925. PhD dissertation, University of Wisconsin-Madison.
- Crowley R (2002) From missiles to milestones: The continuing saga of a building's contribution to the quality of life, *Covance Newsletter*.
- Walters K. Of rats and men: Warfarin becomes world famous by 1955. WARF Decade by Decade; available from: <https://www.warf.org/about-us/history/decade-by-decade/key-events-from-each-decade-in-our-history.cmsx>.
- Whitlon DS, Sadowski JA, and Suttie JW (1978) Mechanism of coumarin action: significance of vitamin K epoxide reductase inhibition. *Biochem* **17(8)**: 1371-1377.
- Stahmann MA, Ikawa M, and Link KP (September 16, 1947) 3-substituted 4-hydroxycoumarin and process of making it. US Patent No. 2,427,578.
- Holmes RW and Love J (1952) Suicide attempt with warfarin, a bishydroxycoumarin-like rodenticide. *JAMA* **148(11)**: 935-937.
- Shapiro S (1953) Warfarin sodium derivative: (Coumadin® Sodium). *Angiology* **4**: 380-390.
- White C (September 22, 2016) "Heart attack strikes Ike," President Eisenhower's 1955 medical emergency in Colorado. *National Archives*; available from: <https://text-message.blogs.archives.gov/2016/09/22/heart-attack-strikes-ike-president-eisenhowers-1955-medical-emergency-in-colorado>.
- Kucharski A (1978) Medical management of political patients: the case of Dwight D. Eisenhower. *Perspect Biol Med* **22(1)**: 115-126.
- Barritt DW and Jordan SC (1960) Anticoagulant drugs in the treatment of pulmonary embolism: a controlled trial. *Lancet* **275(7138)**: 1309-1312.
- Bradley CA (December 14, 2017) Heparin and a VKA—a winning combination. *Nat Rev Cardiol*; DOI: <https://doi.org/10.1038/nrcardio.2017.173>.
- Fernández-Ruiz I (December 14, 2017) High-dose heparin for secondary prevention. *Nat Rev Cardiol*; DOI: <https://doi.org/10.1038/nrcardio.2017.175>.

22. Brown D (August 17, 2007) For the first time, FDA recommends gene testing. *Washington Post*; available from: <http://www.washingtonpost.com/wp-dyn/content/article/2007/08/16/AR2007081602323.html?noredirect=on>.
23. Huynh K (December 14, 2017) Birth of the INR. *Nat Rev Cardiol*; available from: DOI: <https://doi.org/10.1038/nrcardio.2017.176>.
24. FierceBiotech (September 18, 2007) Press Release: FDA clears genetic lab test for warfarin sensitivity; available from: <https://www.fiercebiotech.com/biotech/press-release-fda-clears-genetic-lab-test-for-warfarin-sensitivity>.
25. US Food and Drug Administration (July 3, 2019) Nucleic acid based tests; available from: <https://www.fda.gov/medical-devices/vitro-diagnostics/nucleic-acid-based-tests>.
26. Gage BF, Bass AR, Lin H, Woller SC, Stevens SM, Al-Hammadi N, Li J, Rodriguez T, Miller P, McMillin GA, et al. (2017) Effect of genotype-guided warfarin dosing on clinical events and anticoagulation control among patients undergoing hip or knee arthroplasty. *JAMA* **318**(12): 1115-1124.
27. Huynh K (December 14, 2017) Era of the NOACs. *Nat Rev Cardiol*; DOI: <https://doi.org/10.1038/nrcardio.2017.180>.



The Pharmacologist,
Volume 61,
Number 4,
December 2019



Publish Your Paper in an ASPET Journal

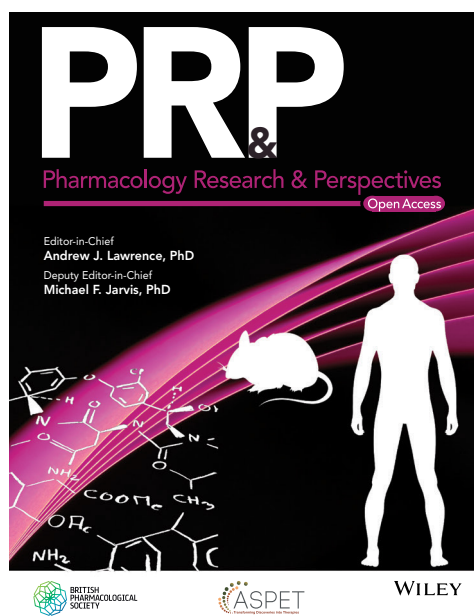
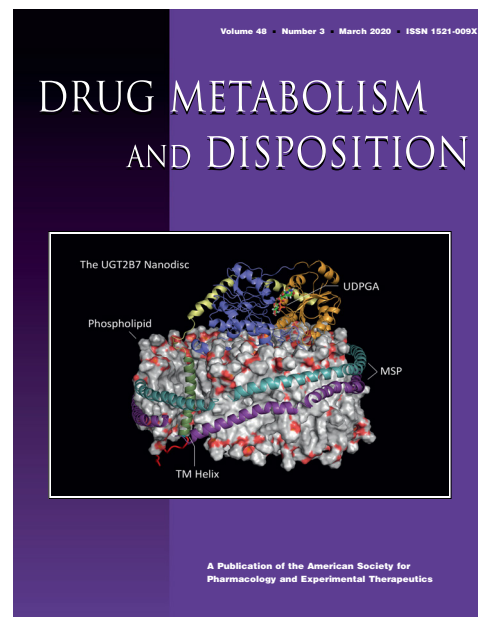
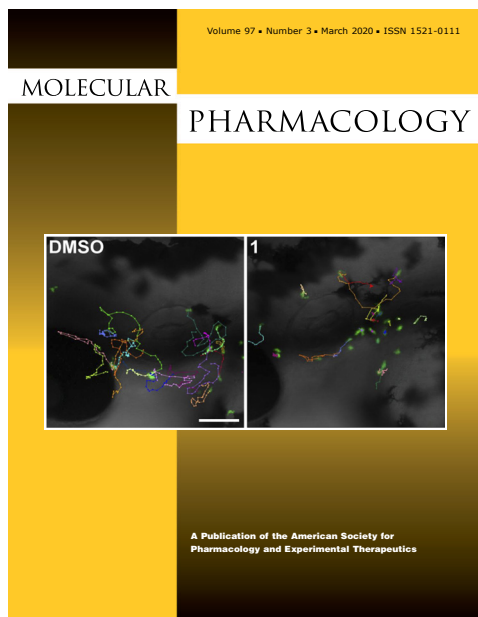

Journals of the American Society
for Pharmacology and Experimental
Therapeutics

ASPETJOURNALS.ORG

Did you enjoy reading these feature articles? Don't miss a single issue of *The Pharmacologist*...

Join the American Society for Pharmacology and Experimental Therapeutics to receive every issue!



Explore the benefits of membership:

- **FREE** online subscription to *The Pharmacologist*
- **Reduced publication fees** to publish in ASPET journals and **FREE** manuscript submission
- **FREE full text online access** to all ASPET journals
- **Reduced registration fees** to attend the ASPET Annual Meeting at Experimental Biology and other related meetings
- **Email notifications** of events and opportunities of specific interest to members
- **Opportunities to present your work** at the ASPET Annual Meeting
- **Networking** and **career opportunities** among fellow colleagues, faculty, and members that are doing research in your field of study
- **Travel awards** and **poster competitions** for students and young scientists
- **Advocacy** for research funding and **science policy** favorable to pharmacology and biomedical research
- Access to members-only online community, **ASPETConnect**
- Access to the **ASPET Career Center** and **reduced pricing** to post jobs

To learn more and to apply,
visit www.aspet.org/membership/benefits

